

للعالمين 

Paper activities

Introductory level

We color, think,
compare and learn
together

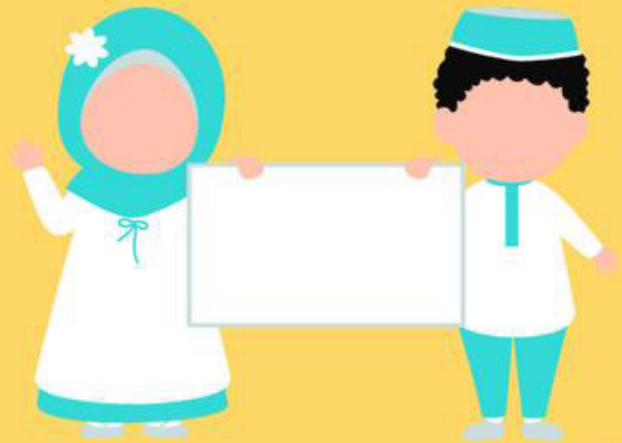

In this file



Find the difference
Connect the similar
Coloring sheets
Connect the shadow
Where is it located?

Connect the dots
Differences between
the two pictures
Color by numbers
Assemble puzzles

Note:

This file contains colored pictures, so it is preferable to print them in color to make them easier to work with.

للعالمين 

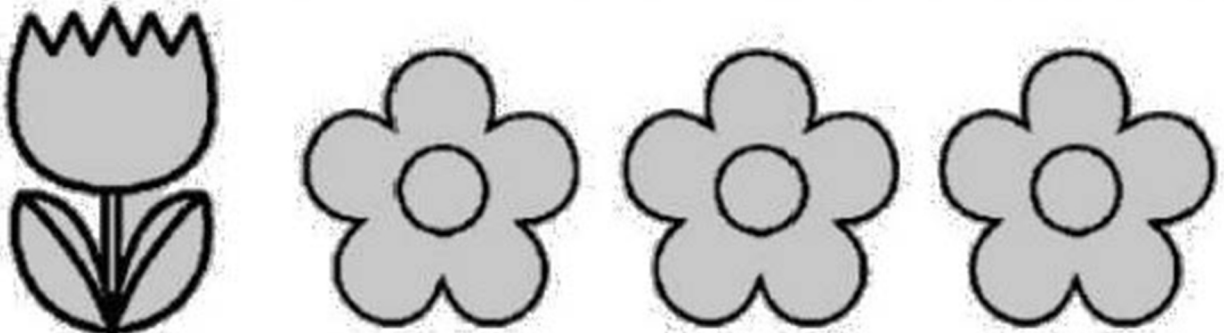
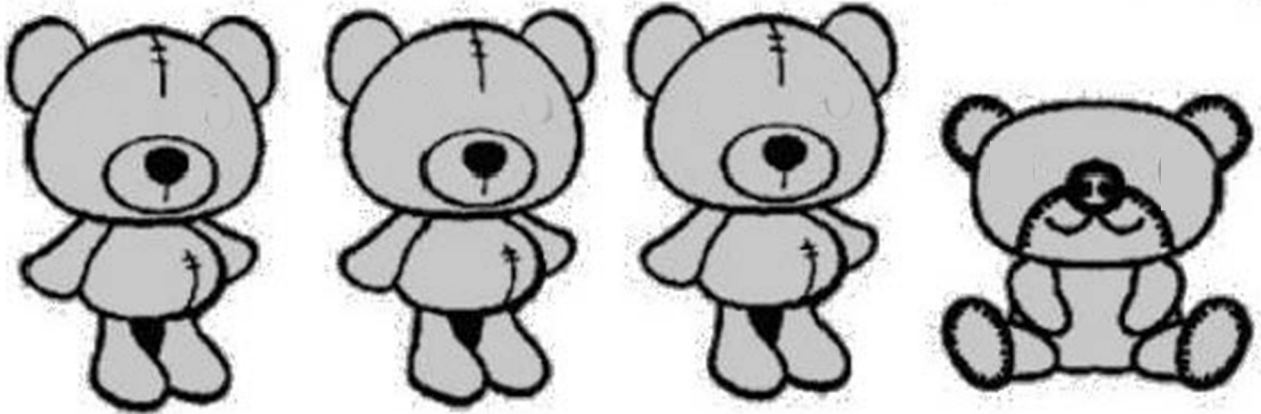
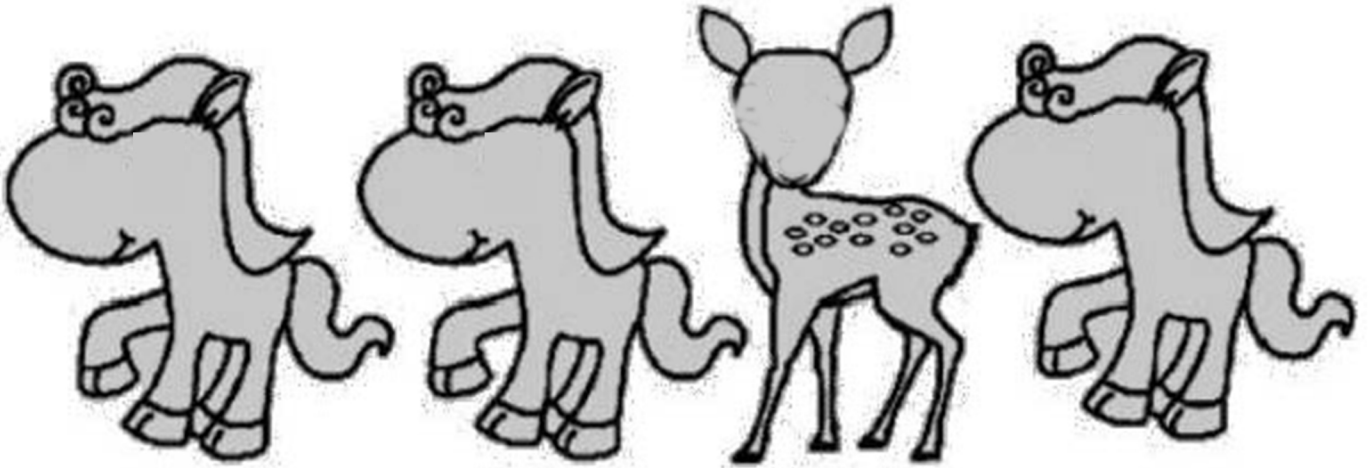
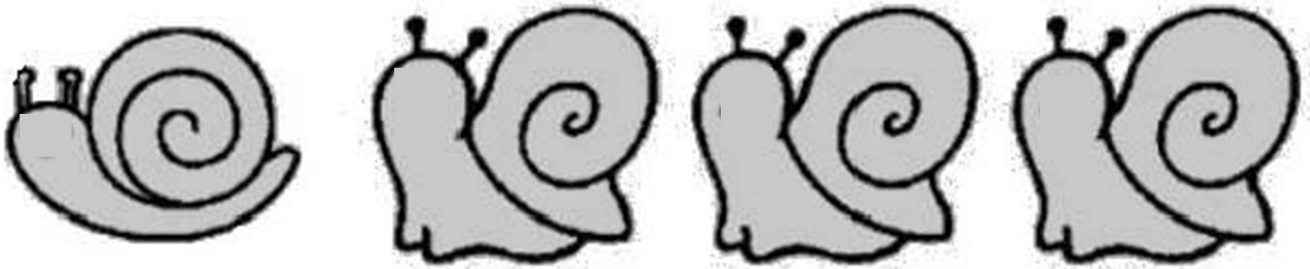

Select the different shape

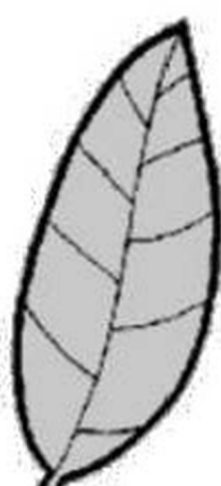

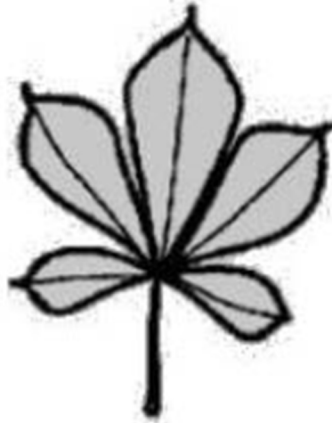
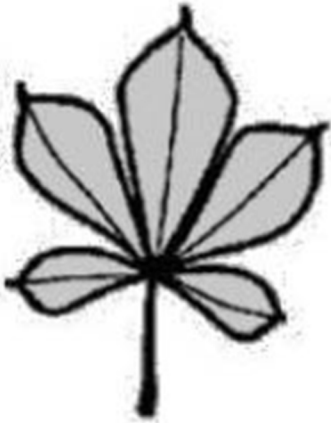

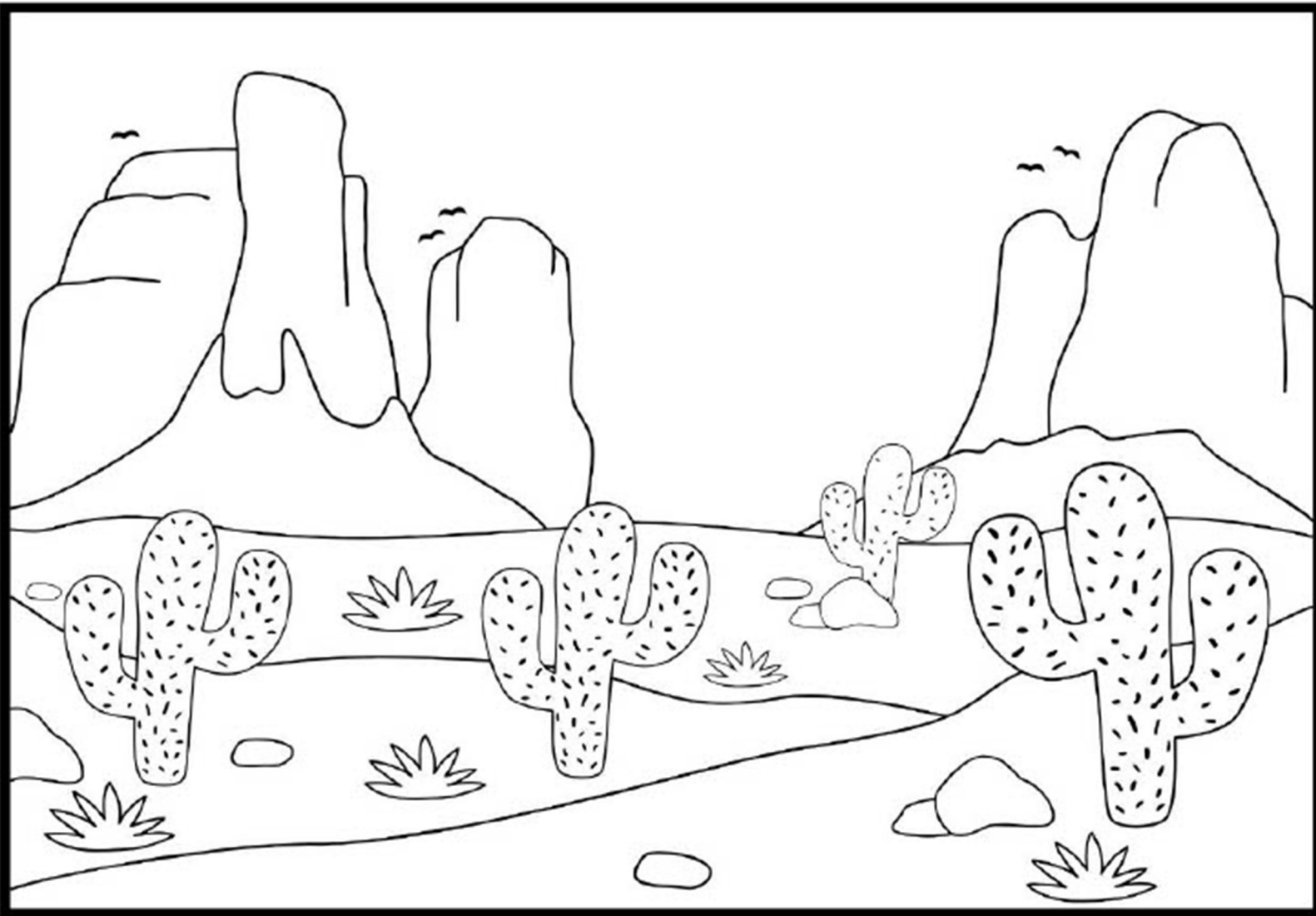

To color



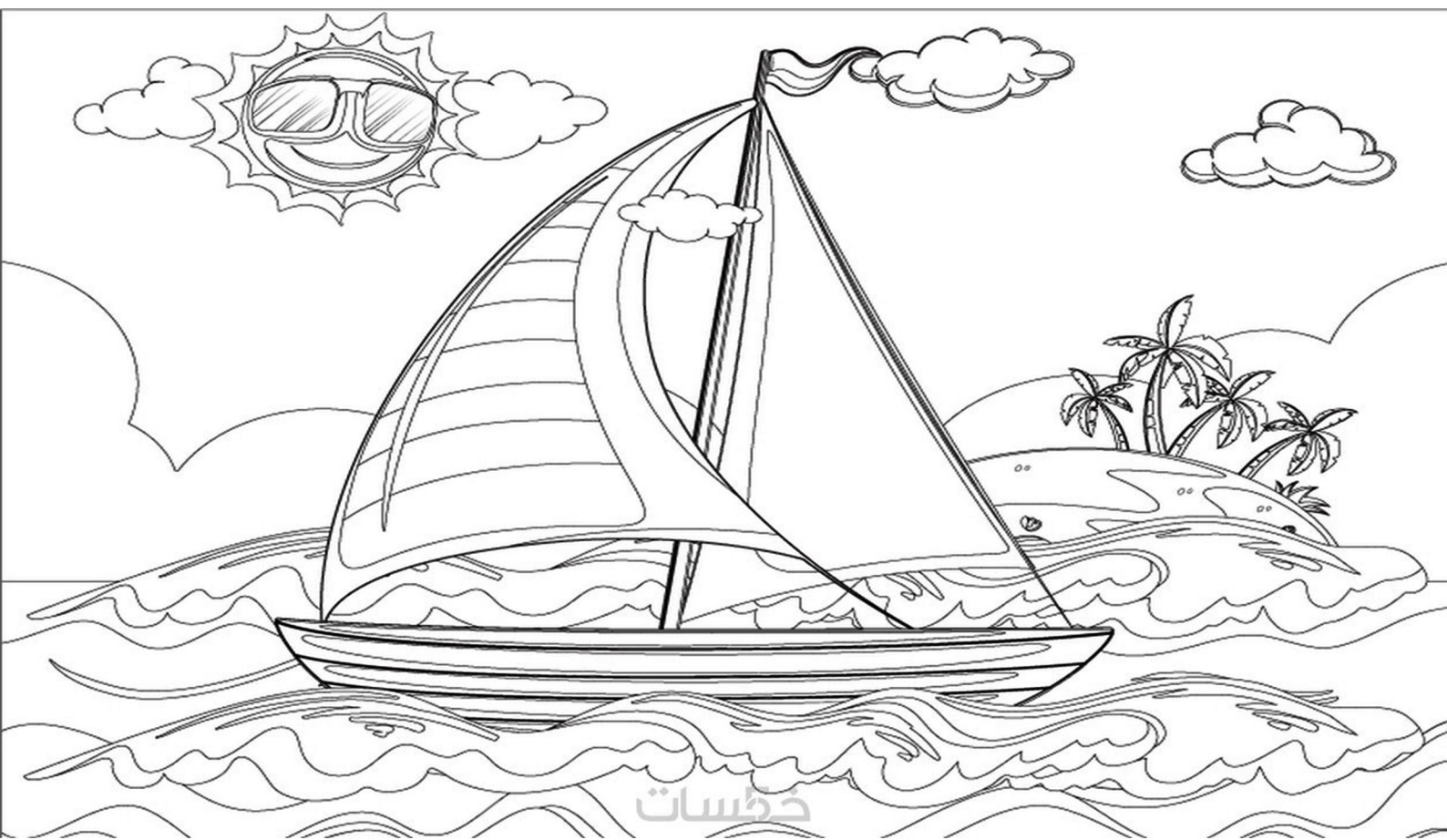



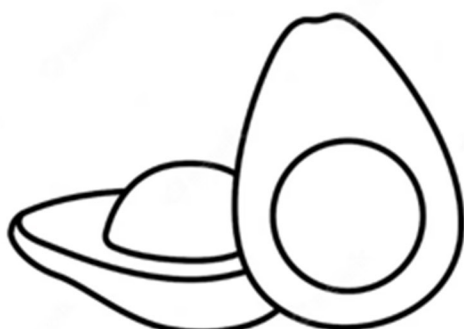
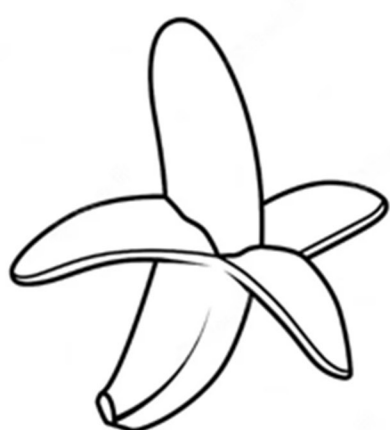

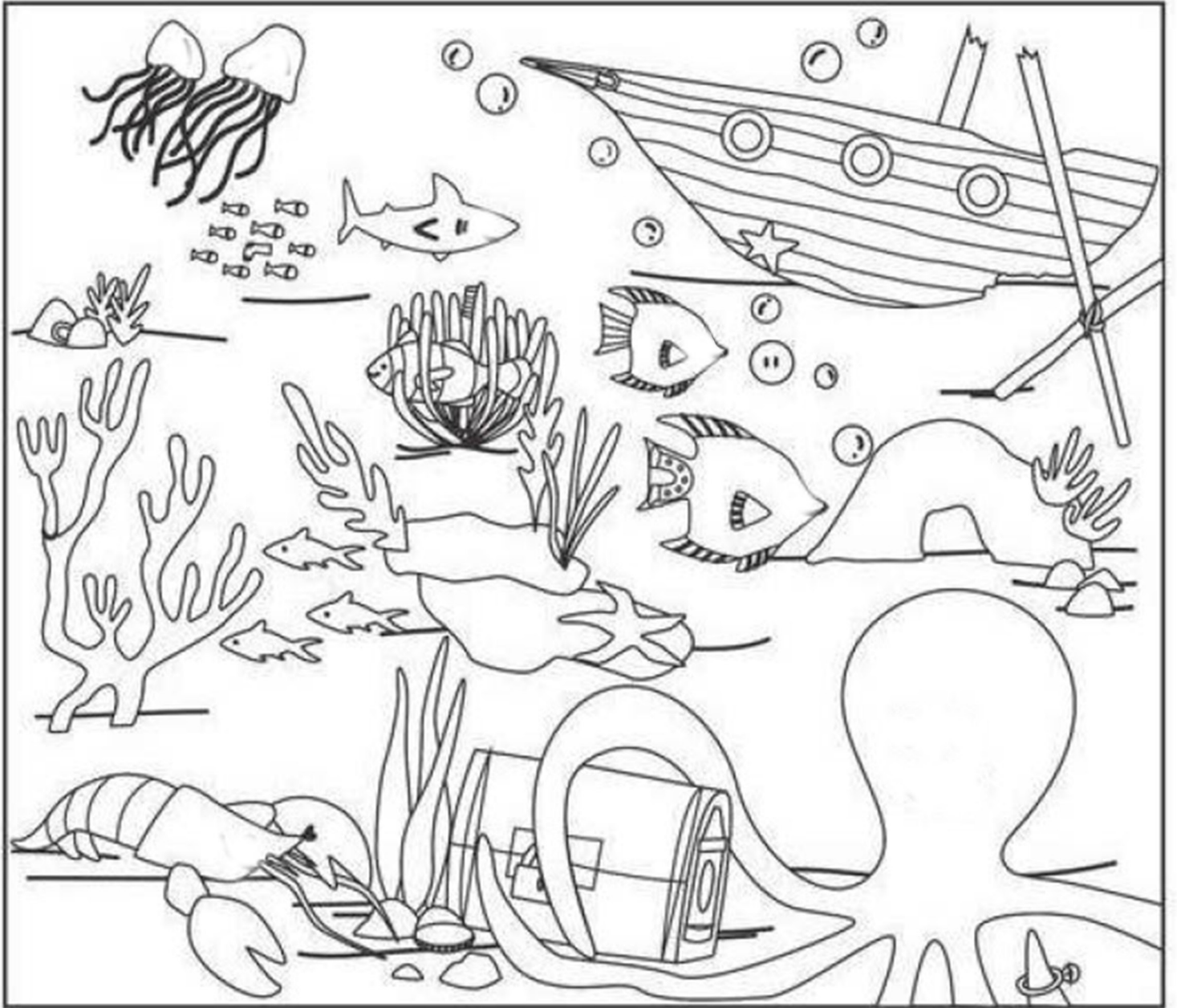

Connect the similar

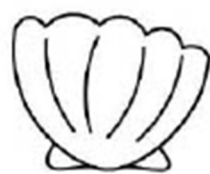
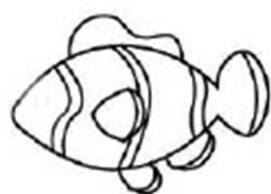
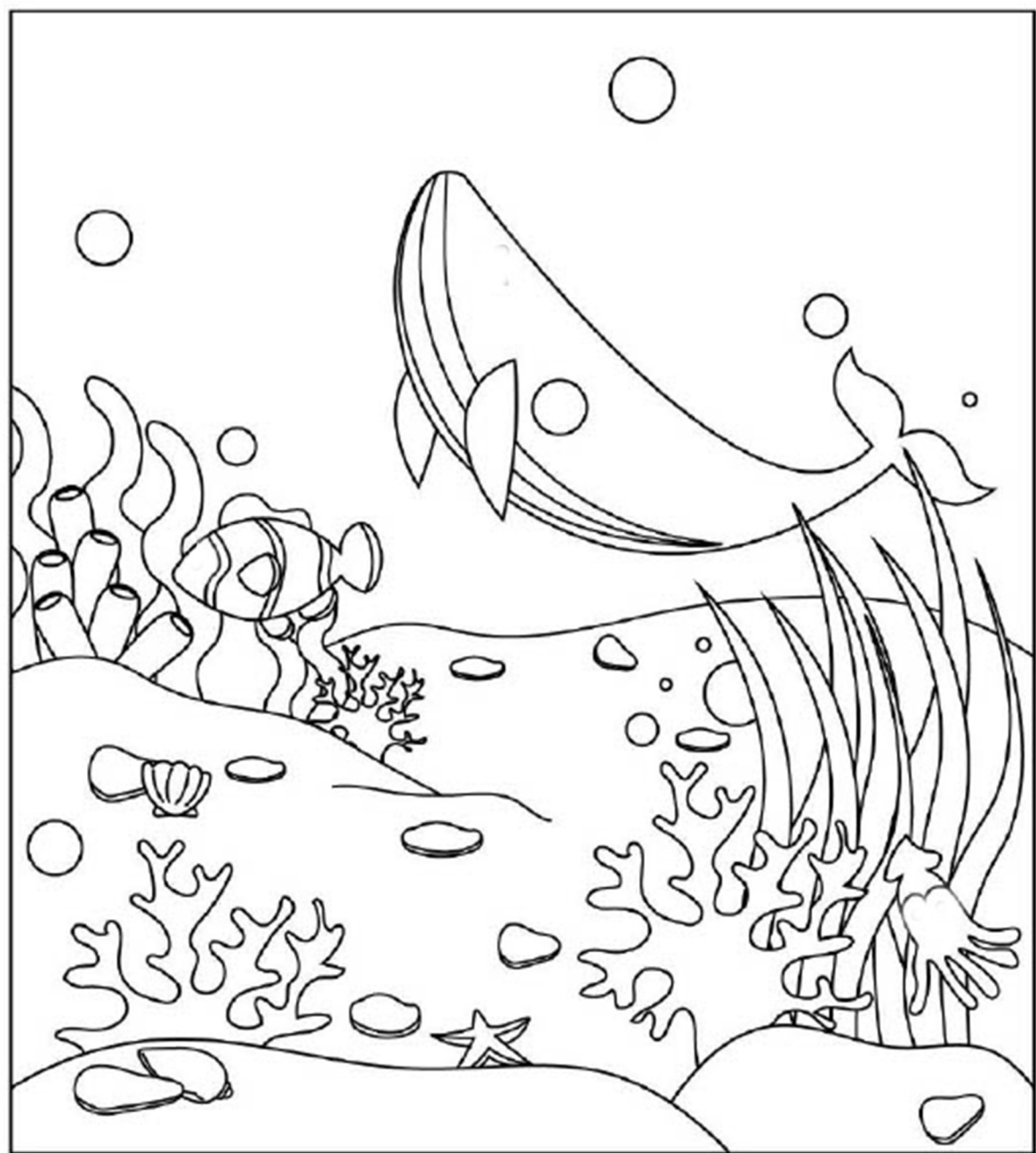

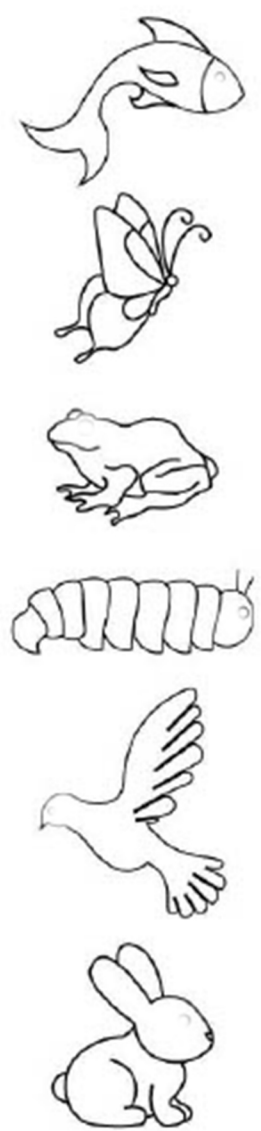

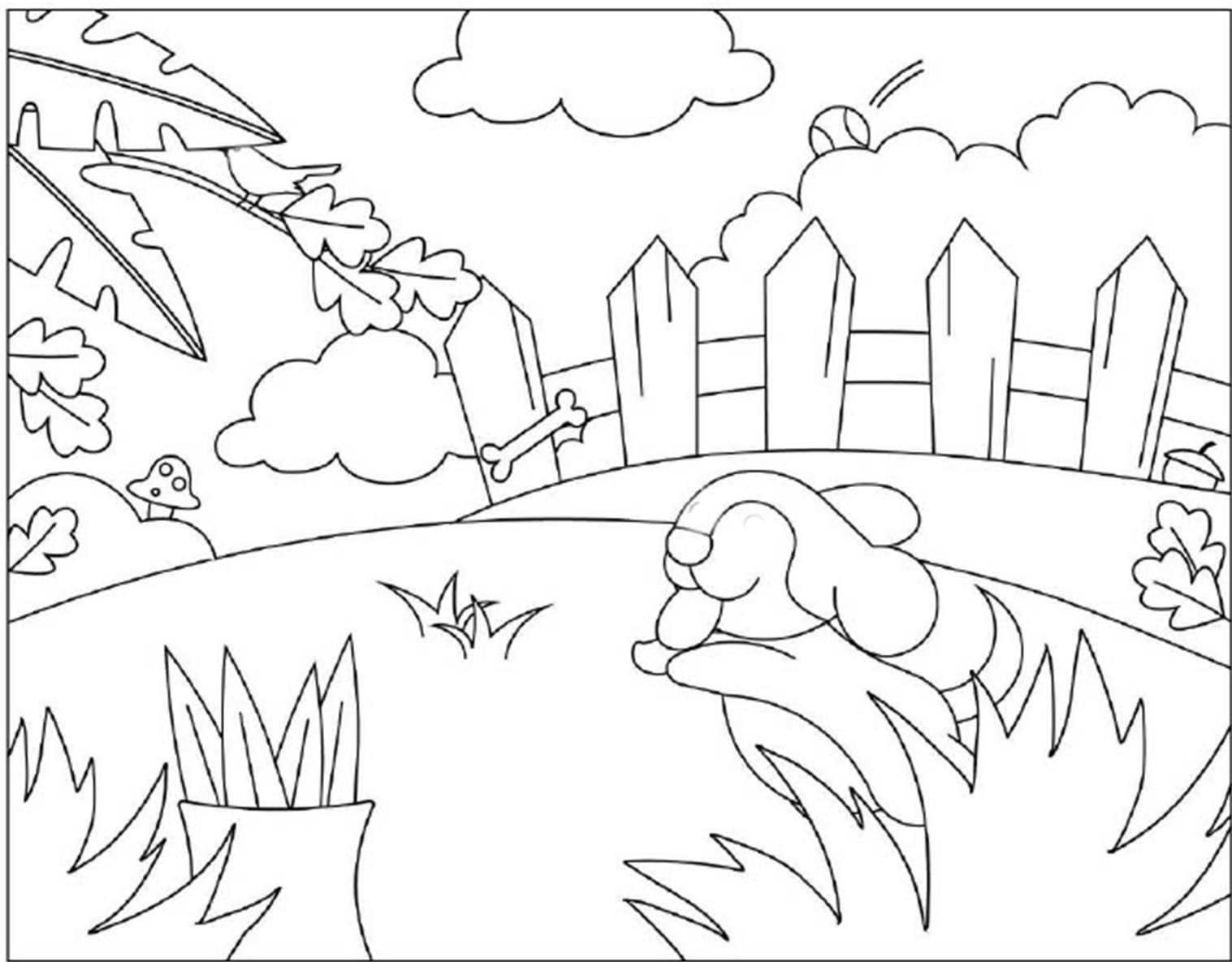

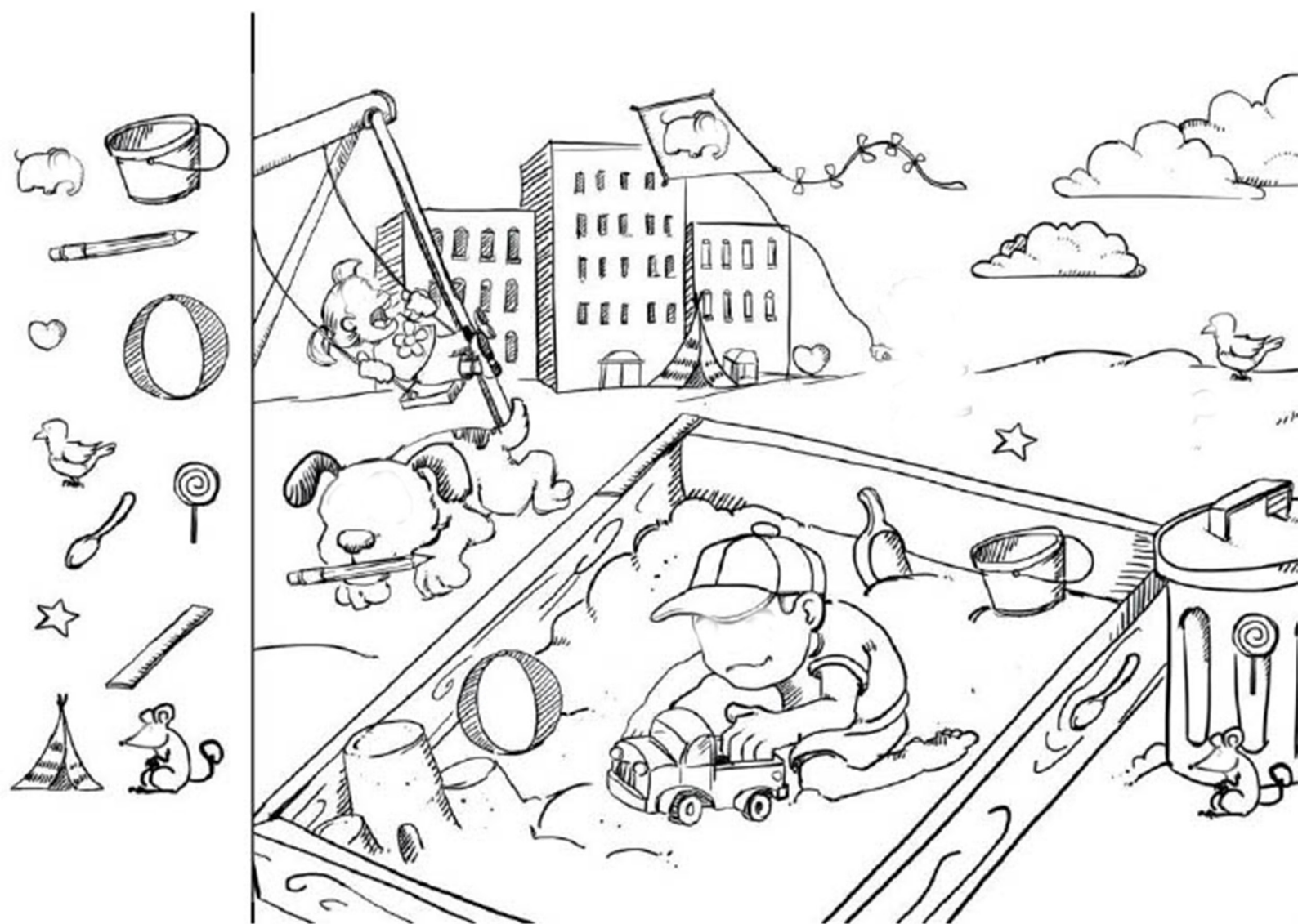



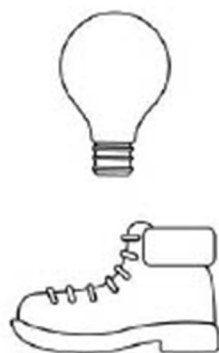
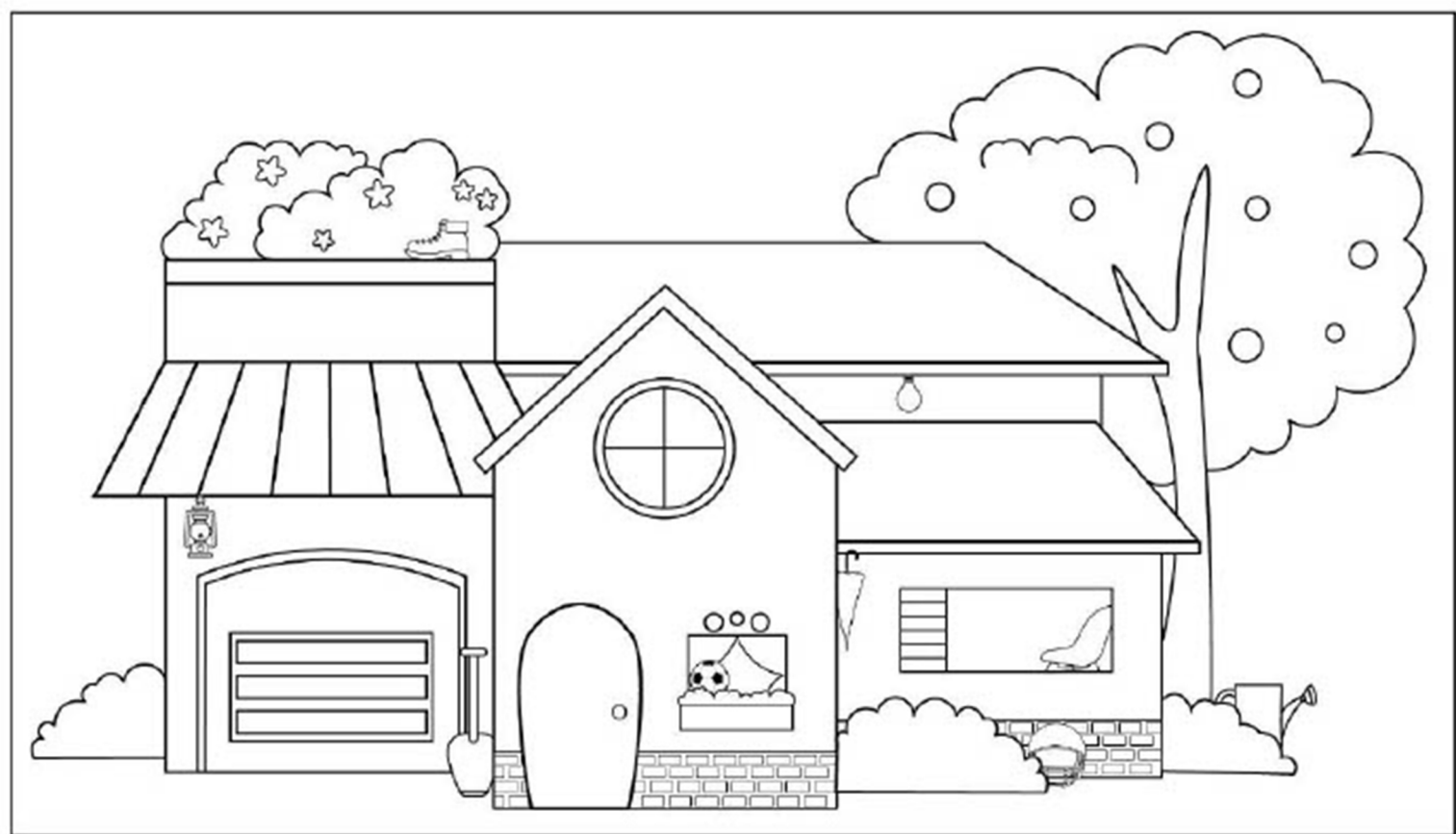

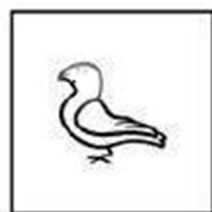
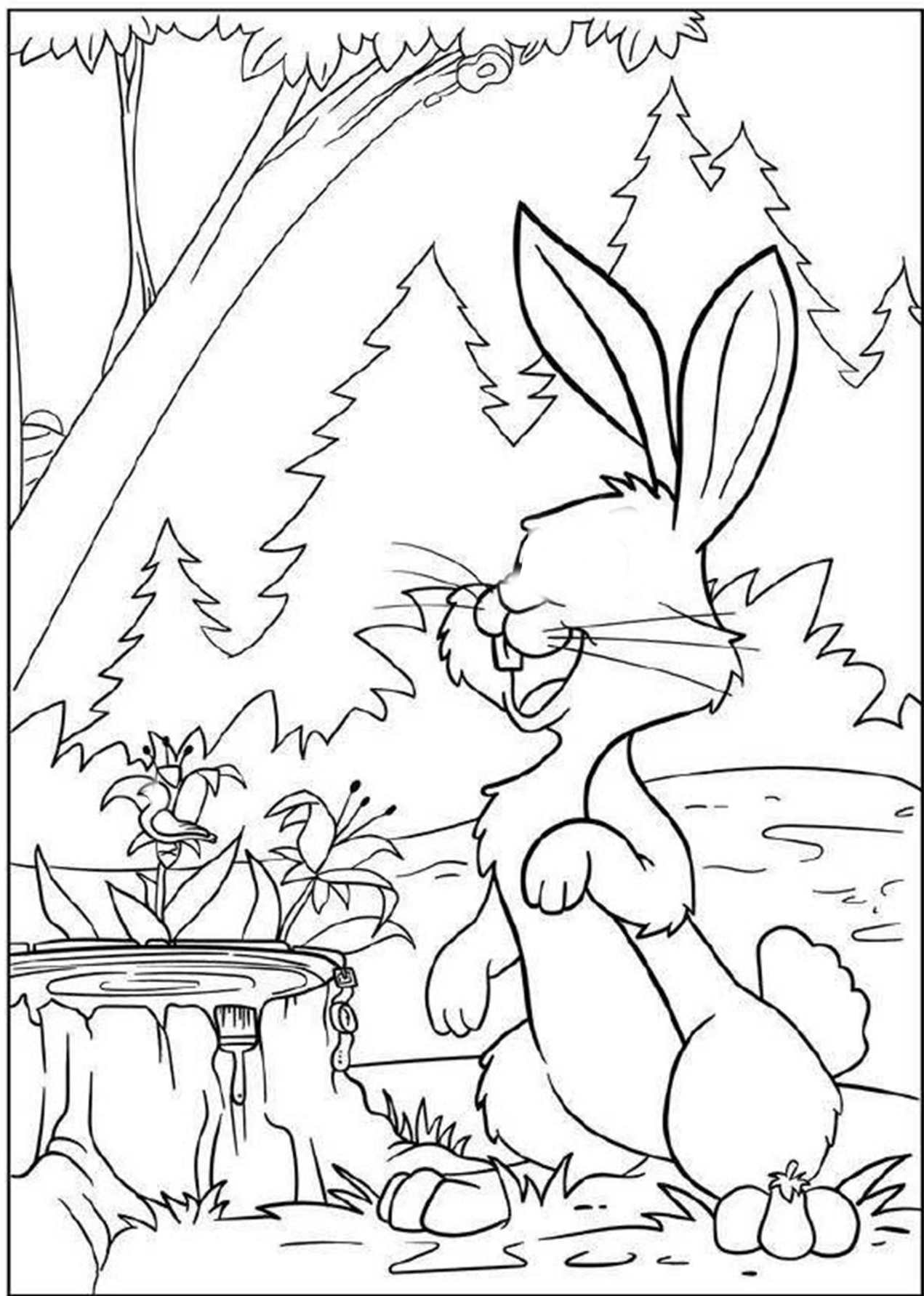

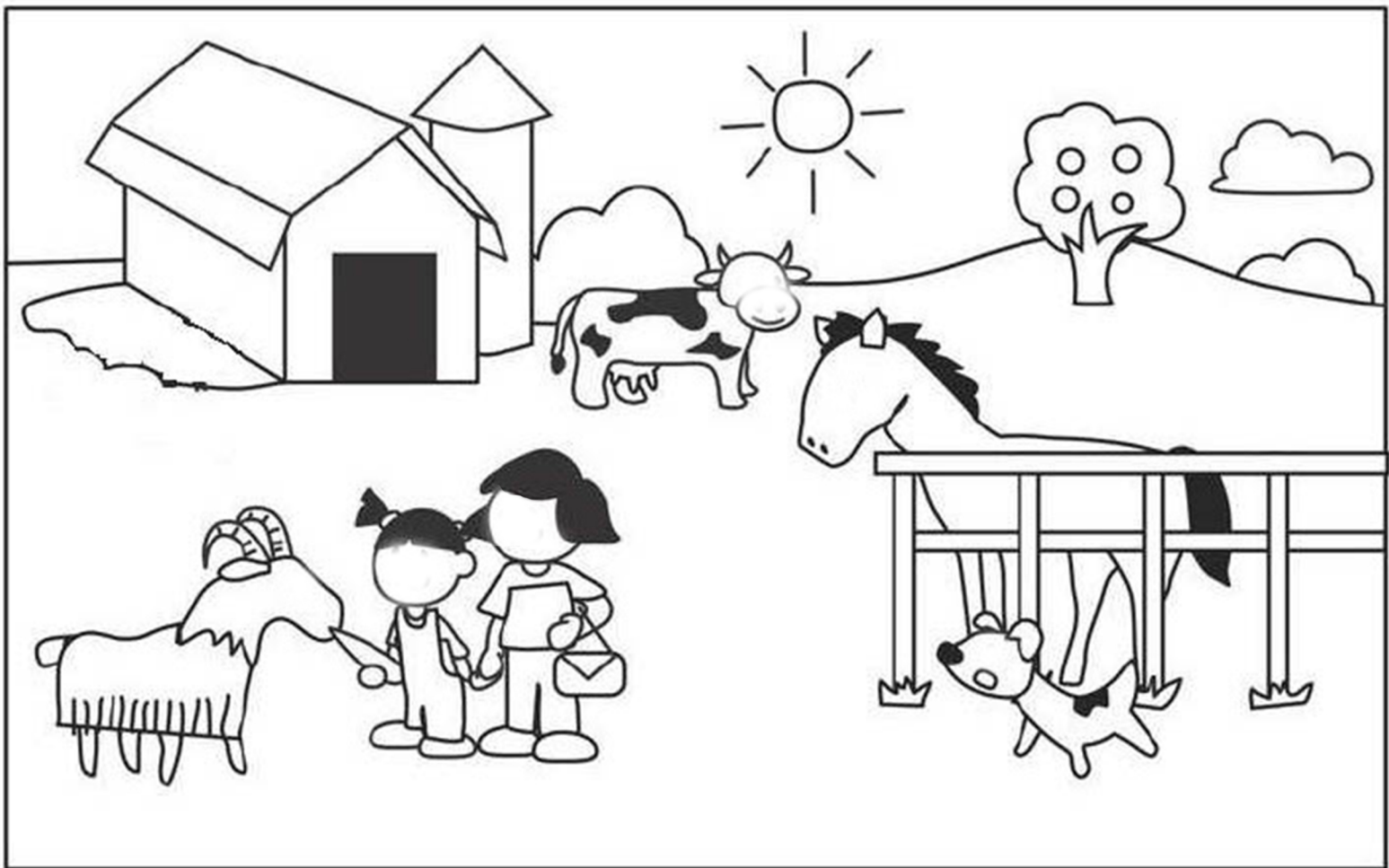
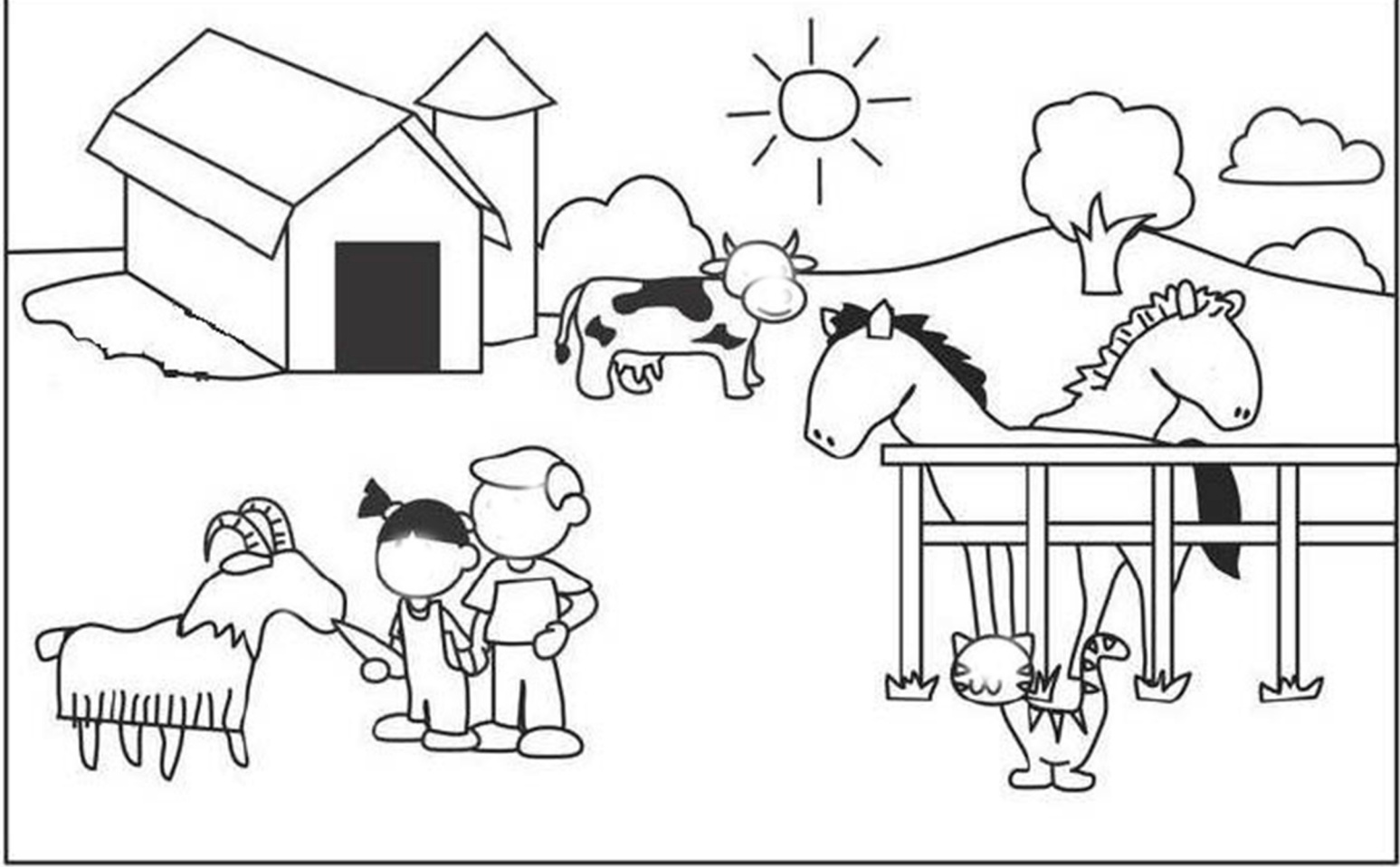

Find the difference between the two pictures



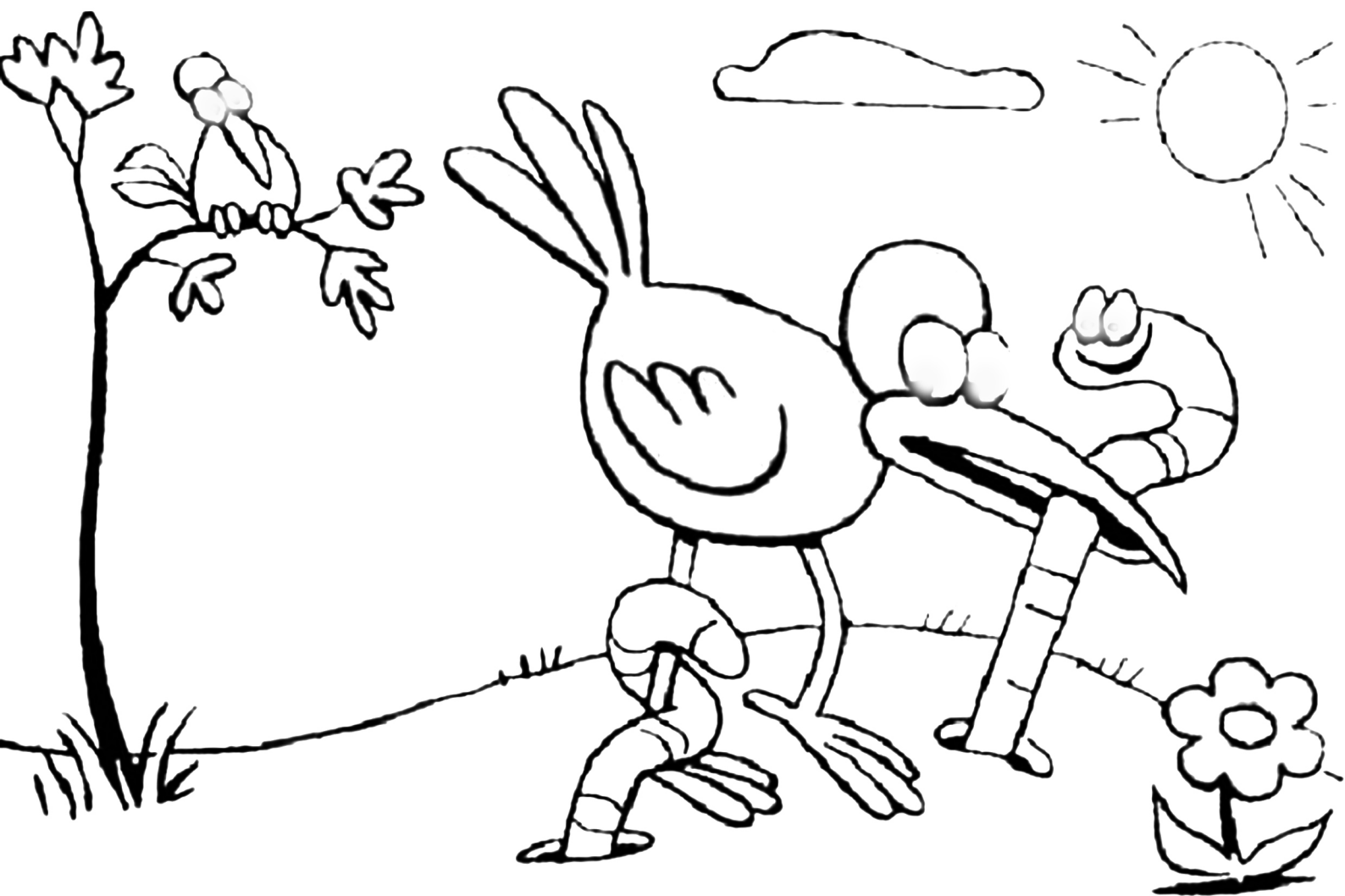
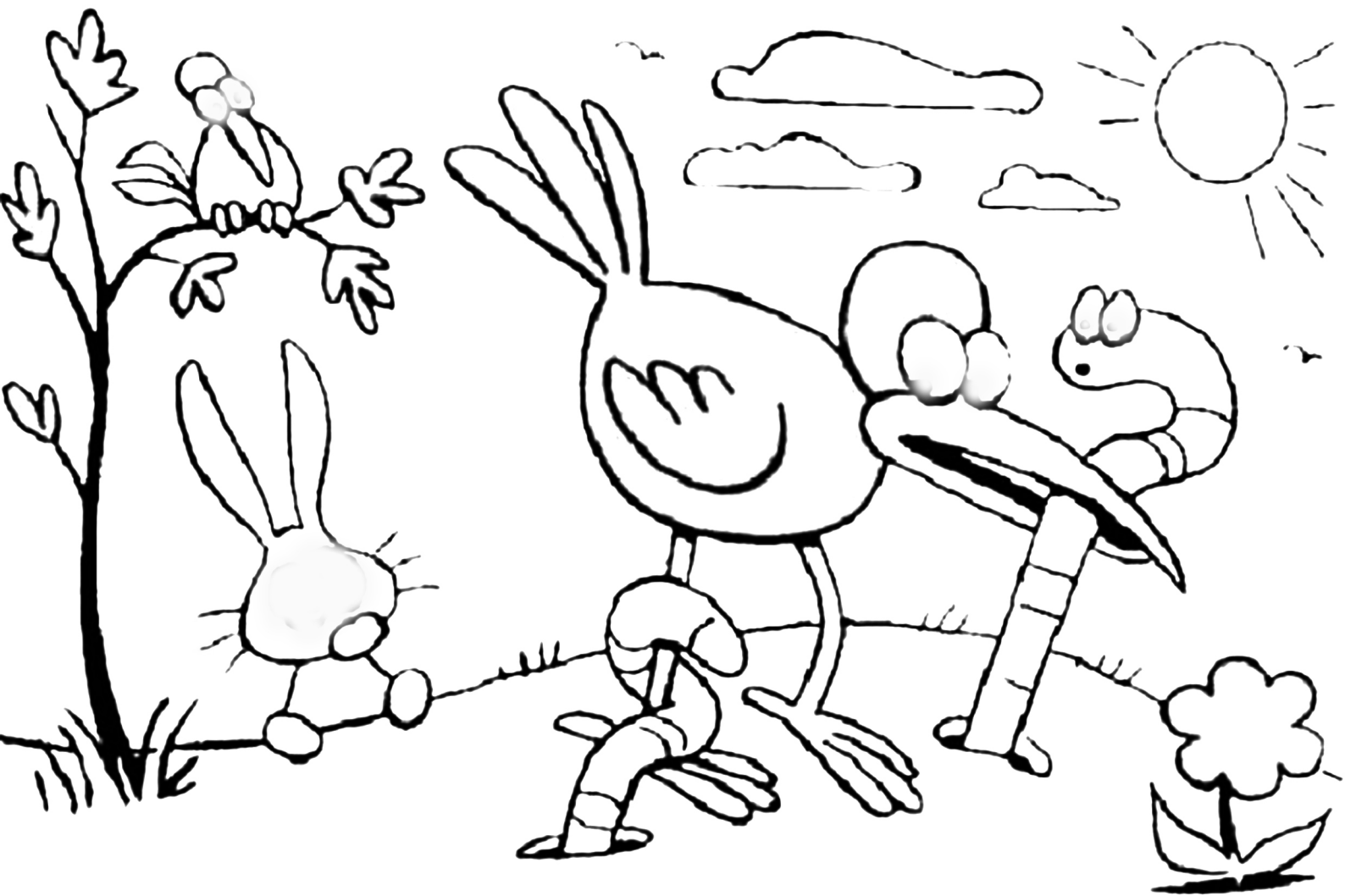

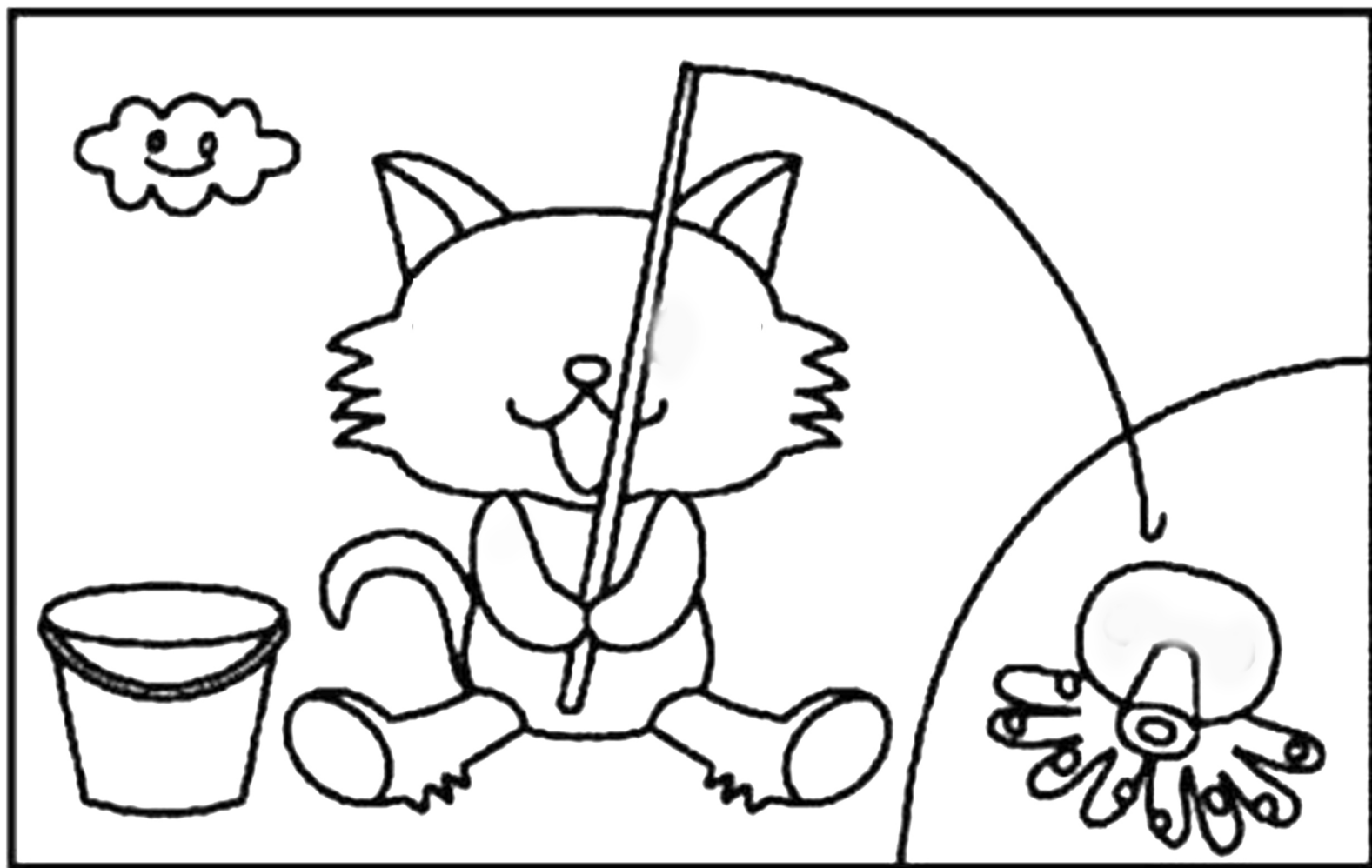
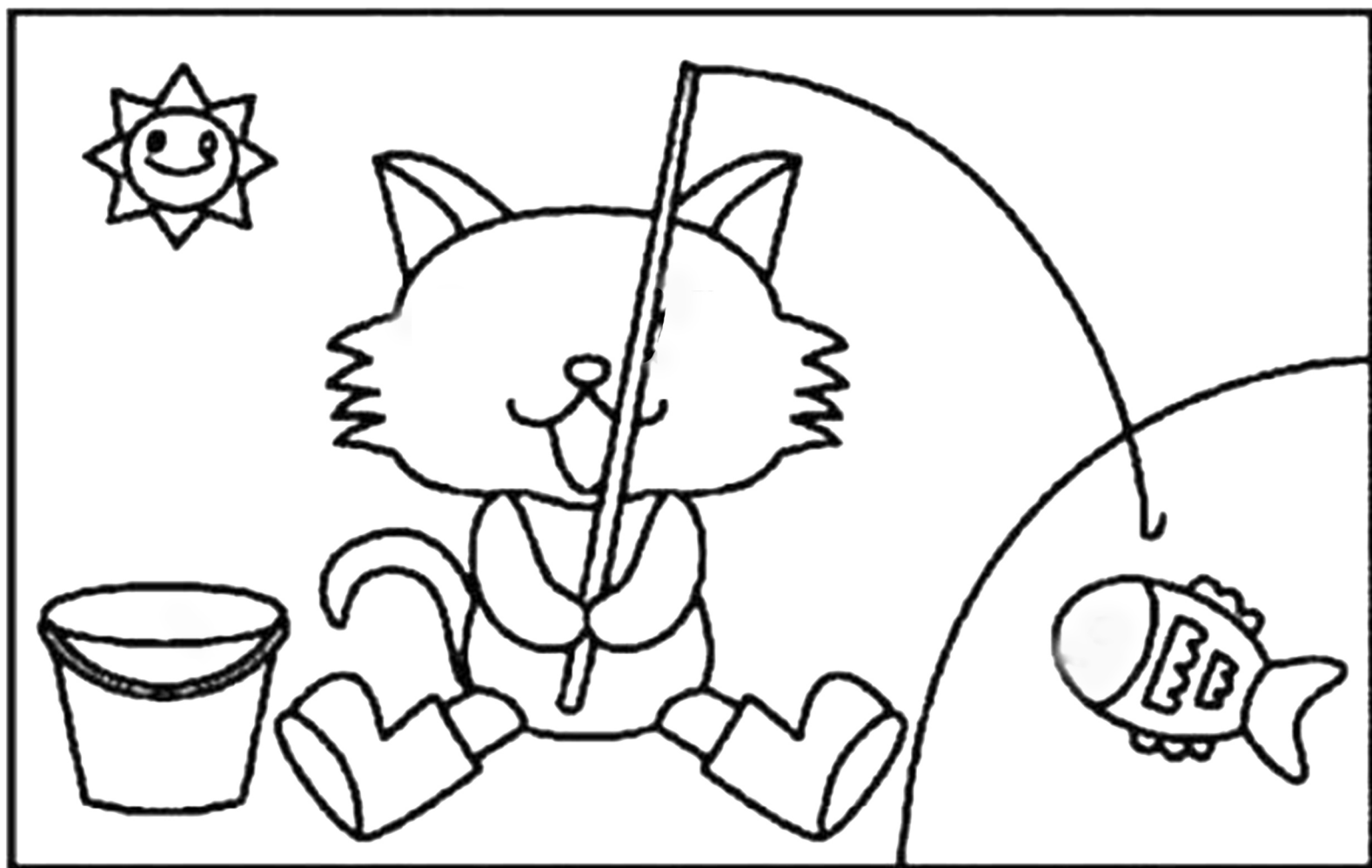

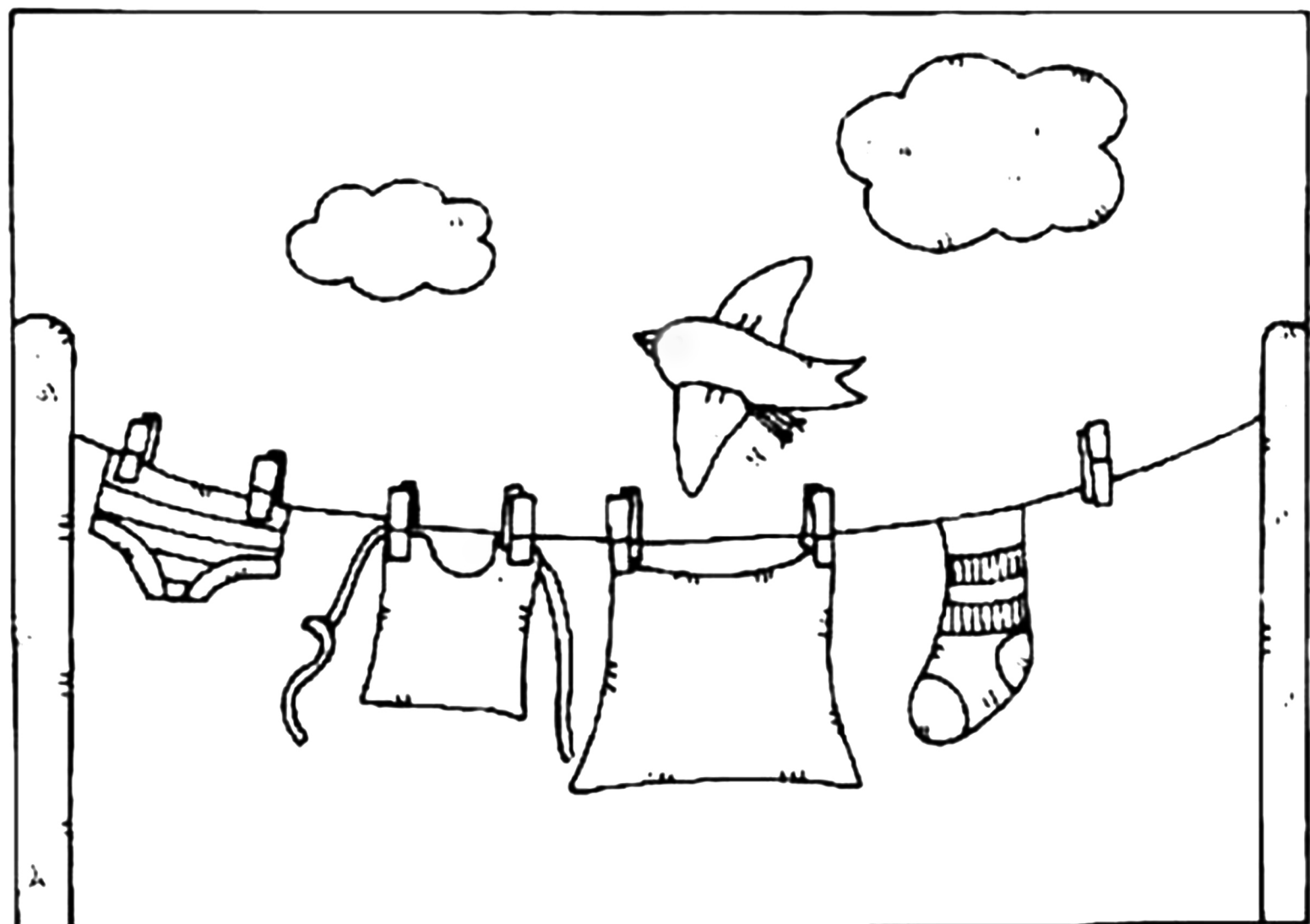
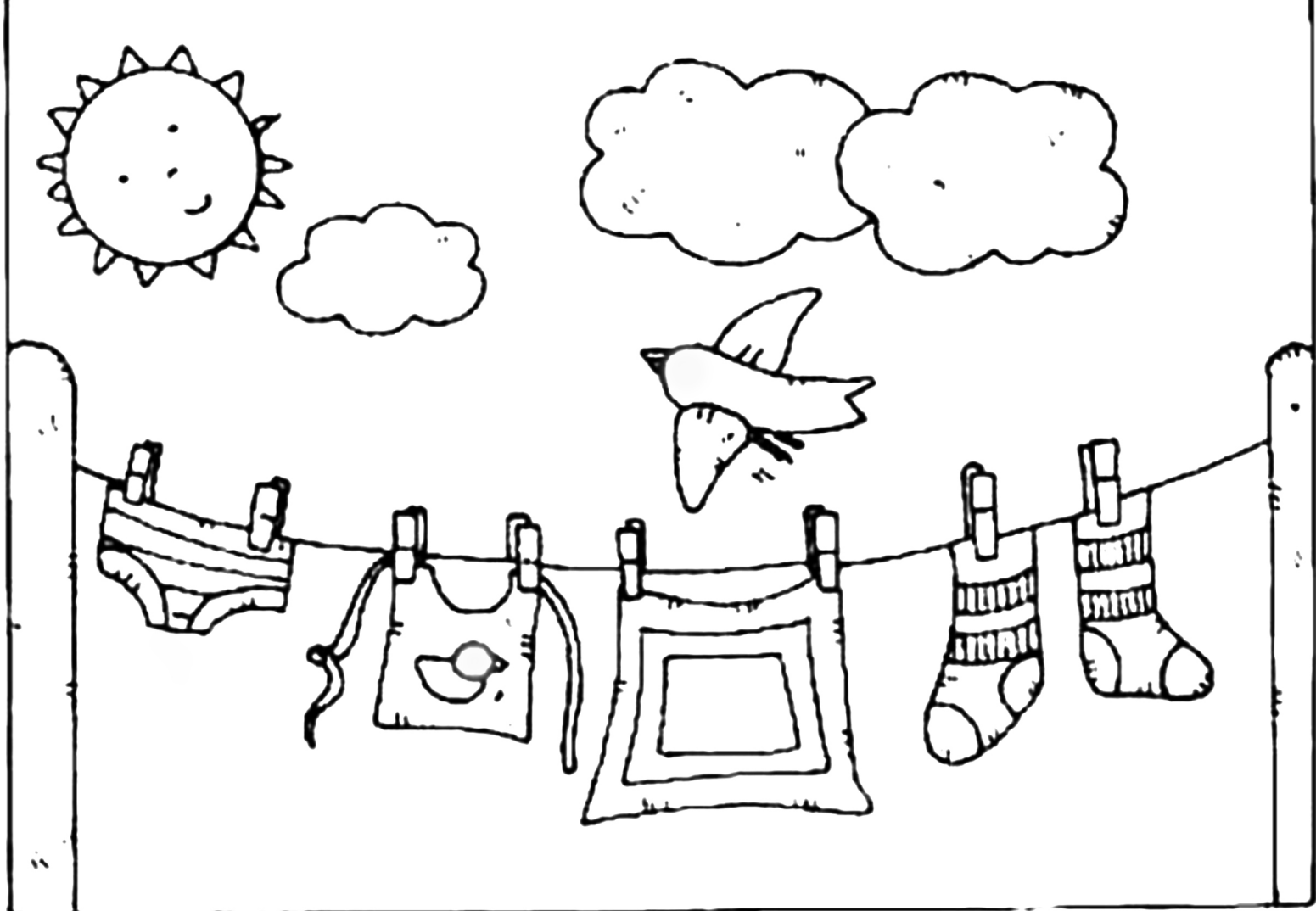

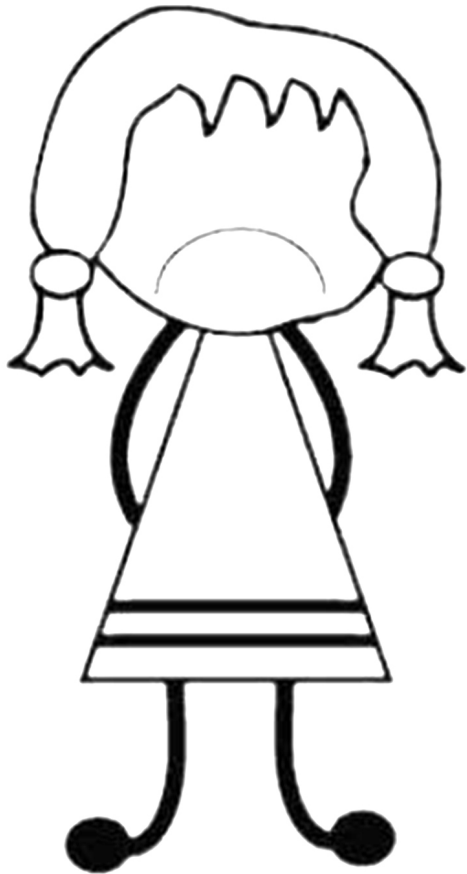
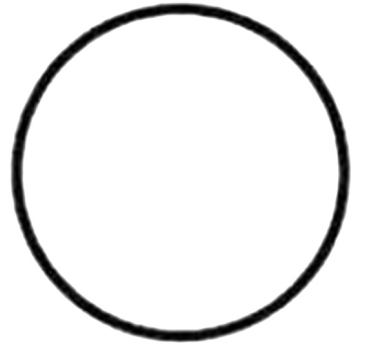
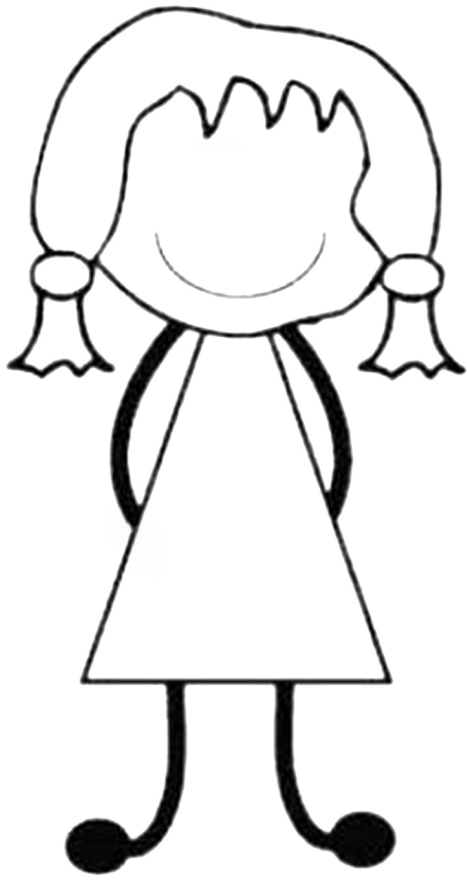

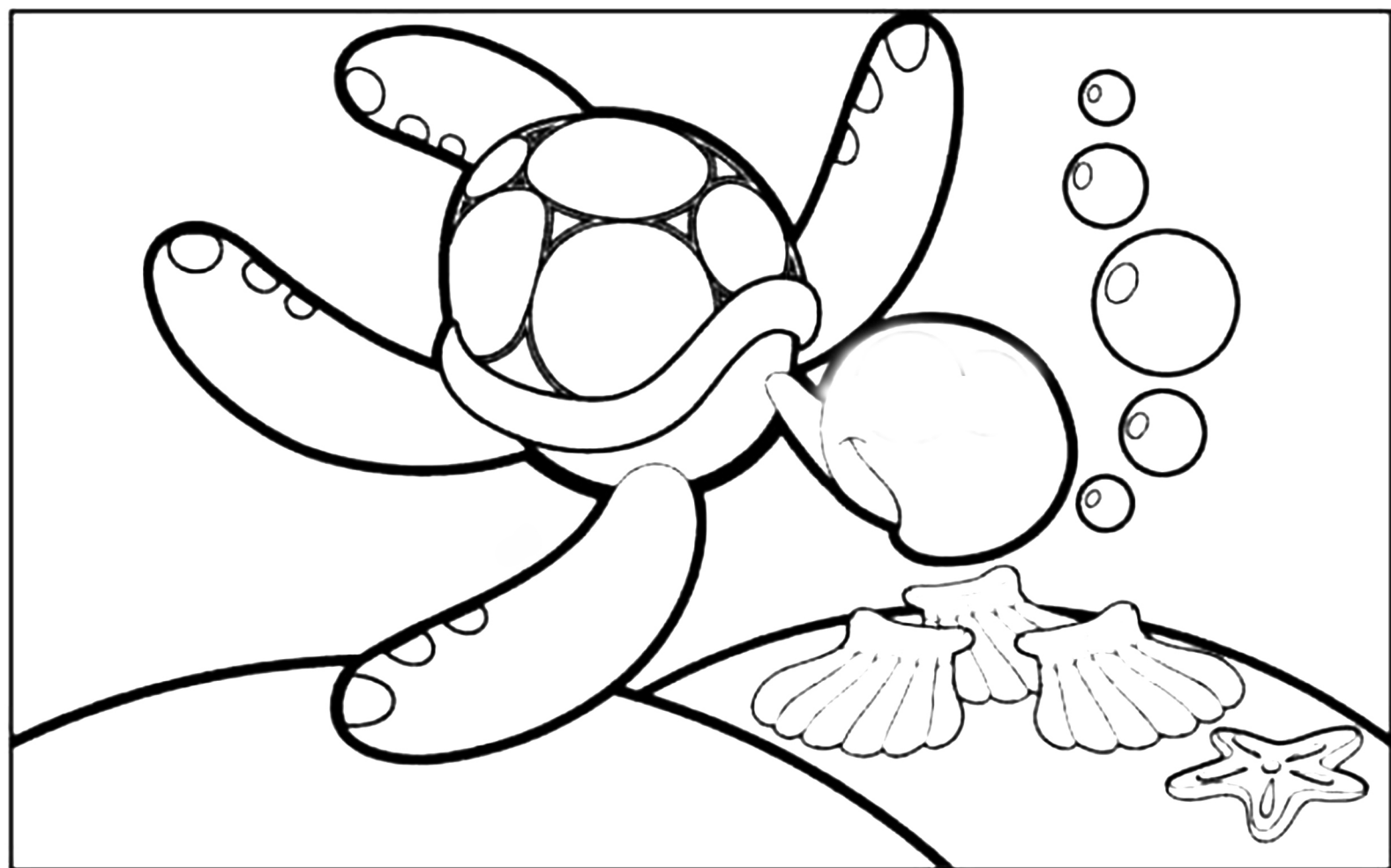
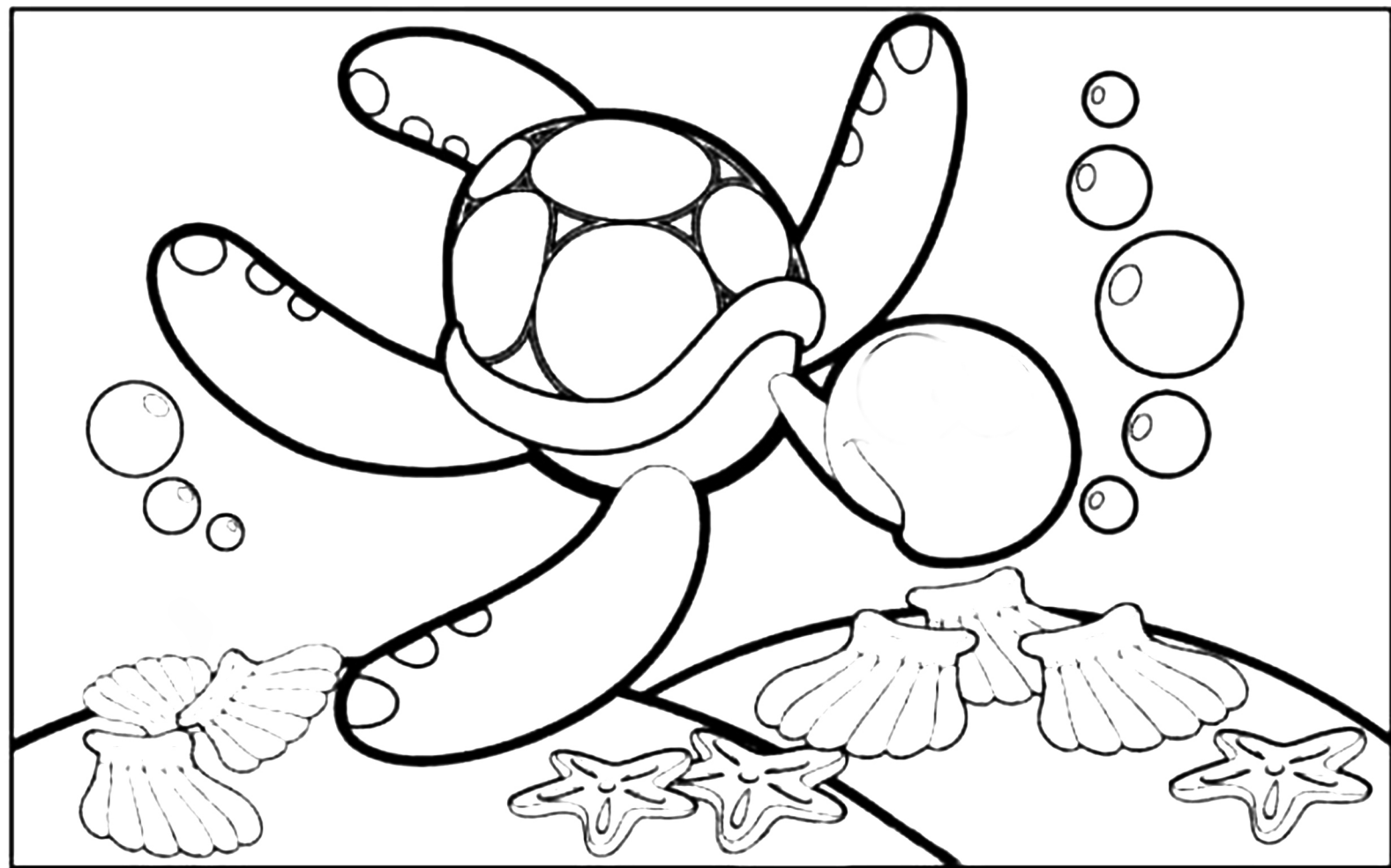



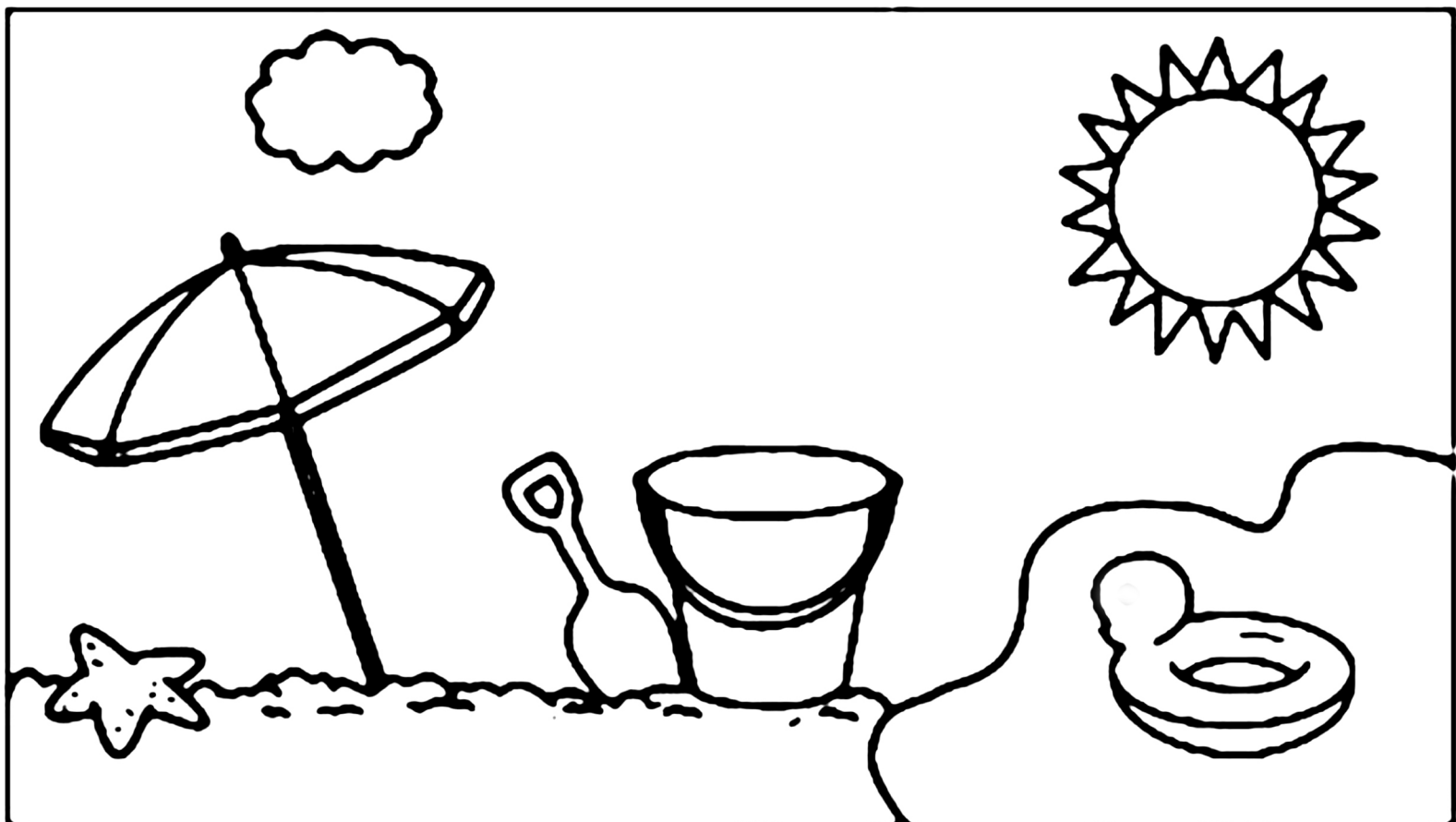
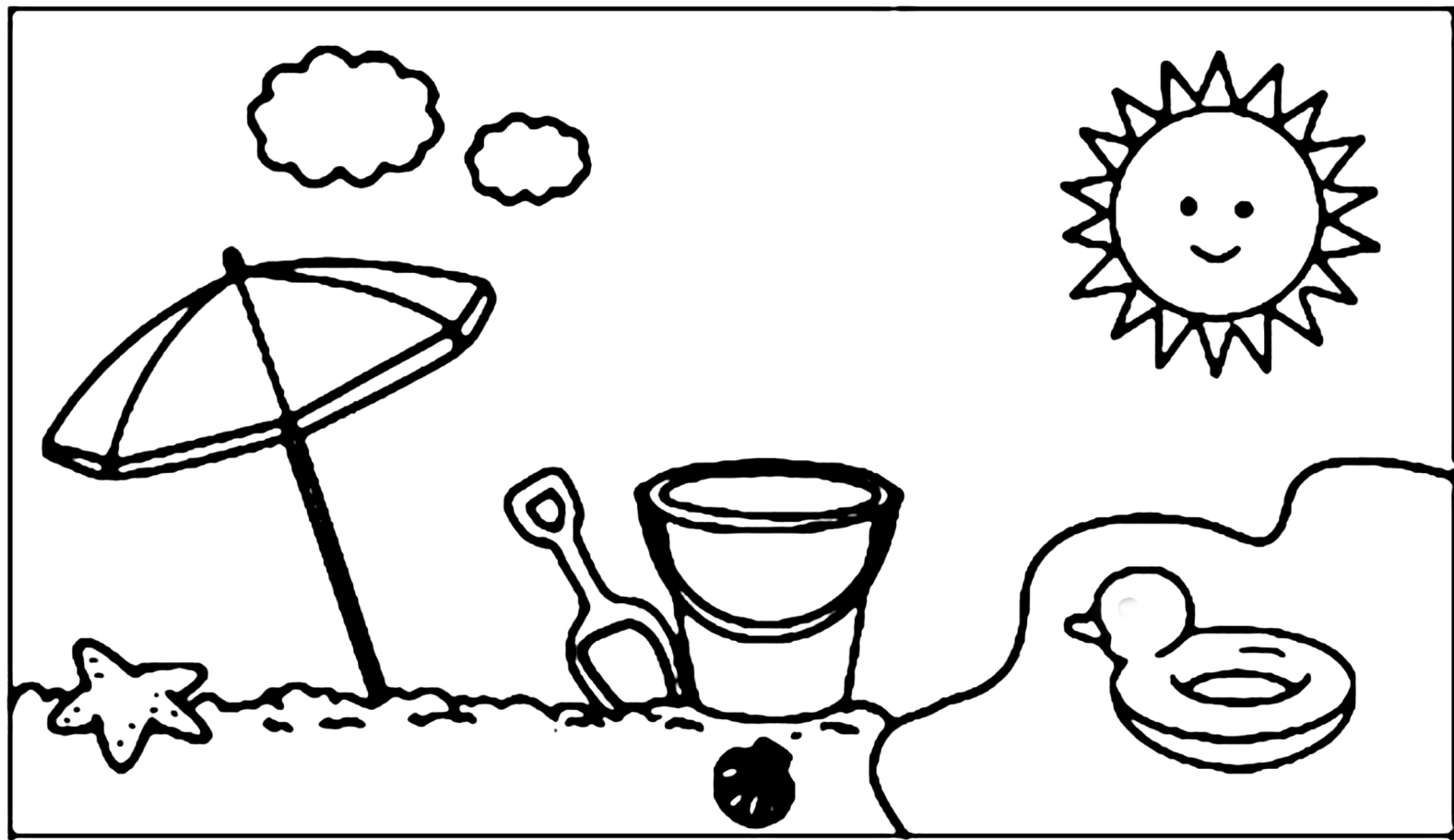

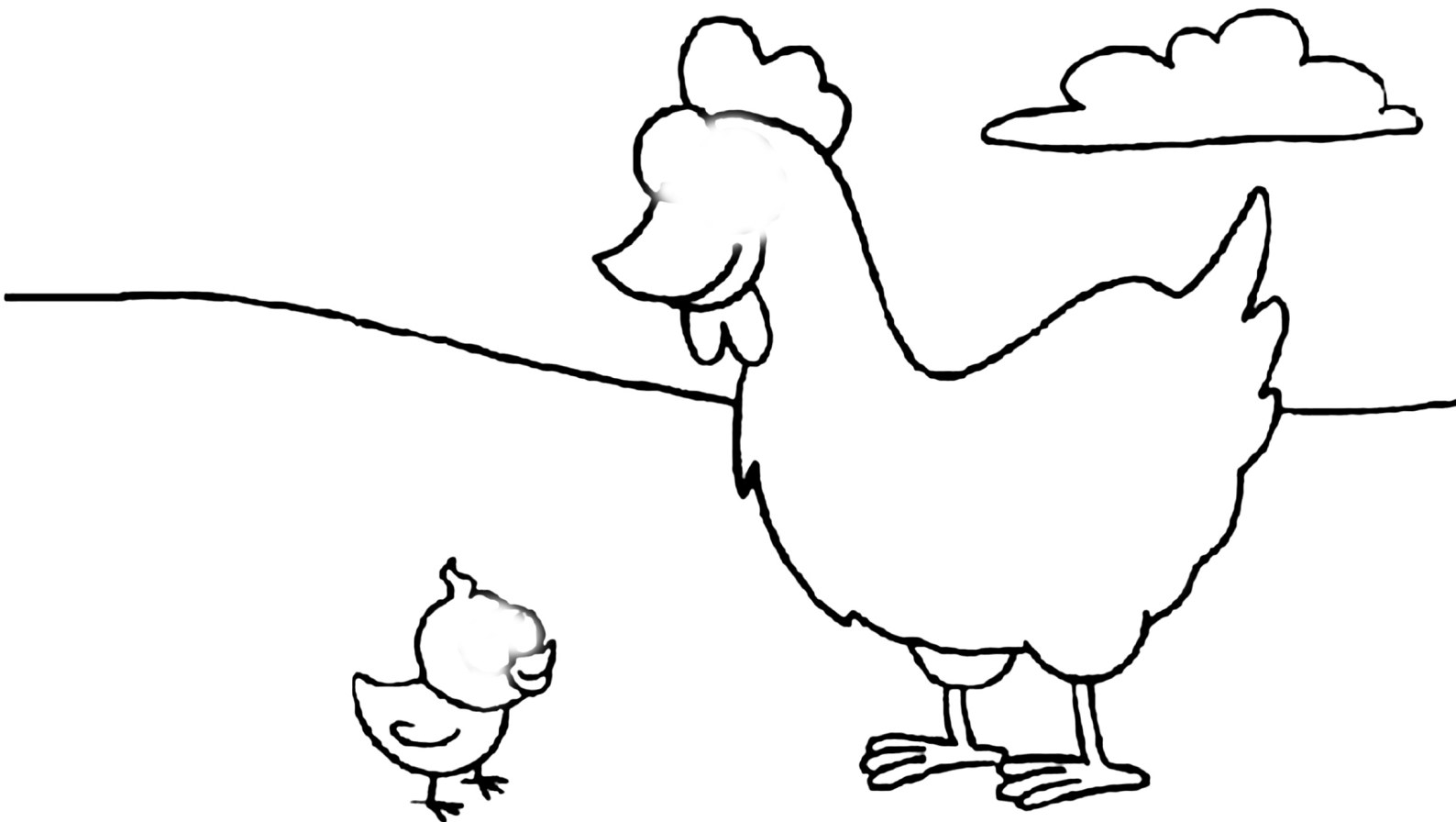
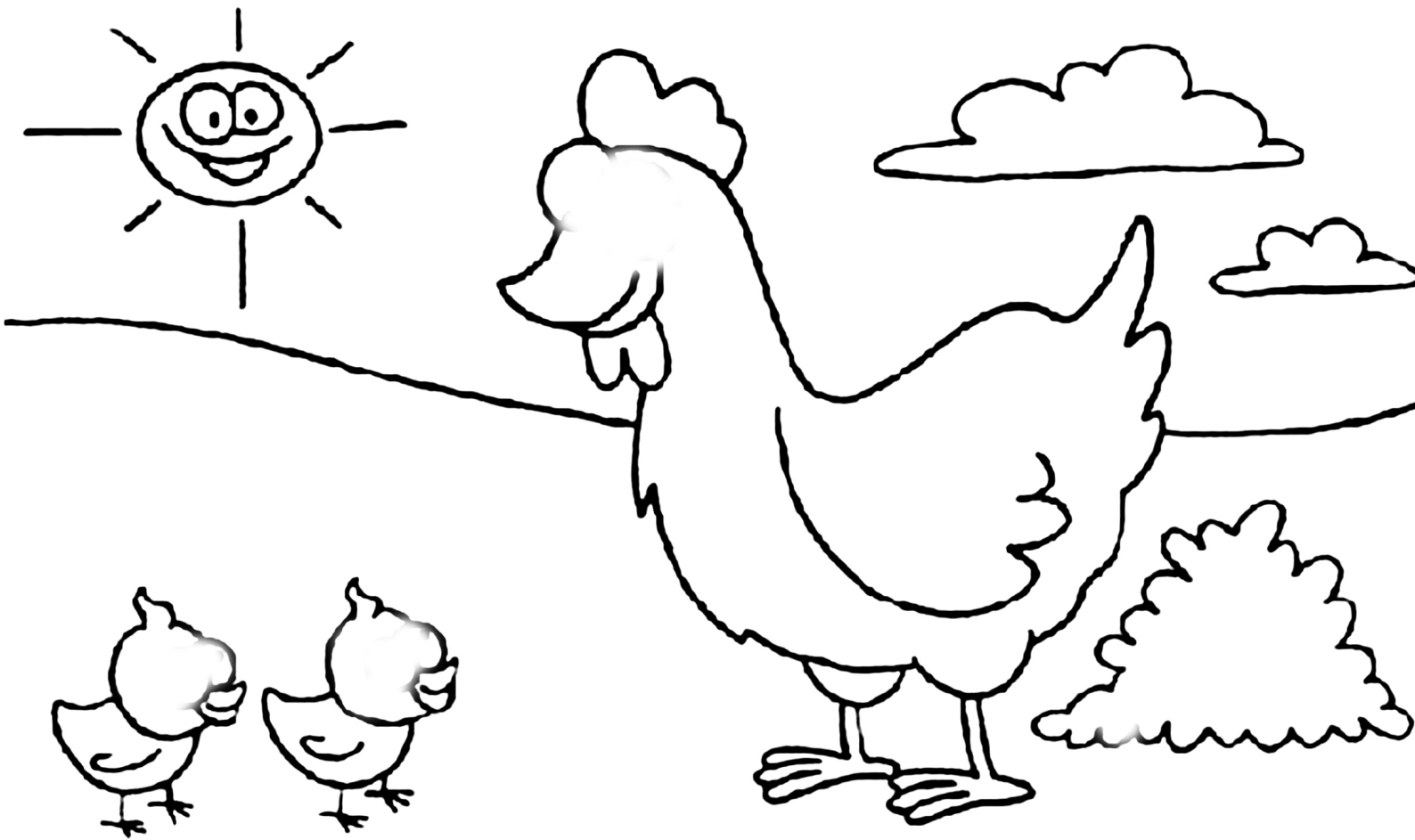

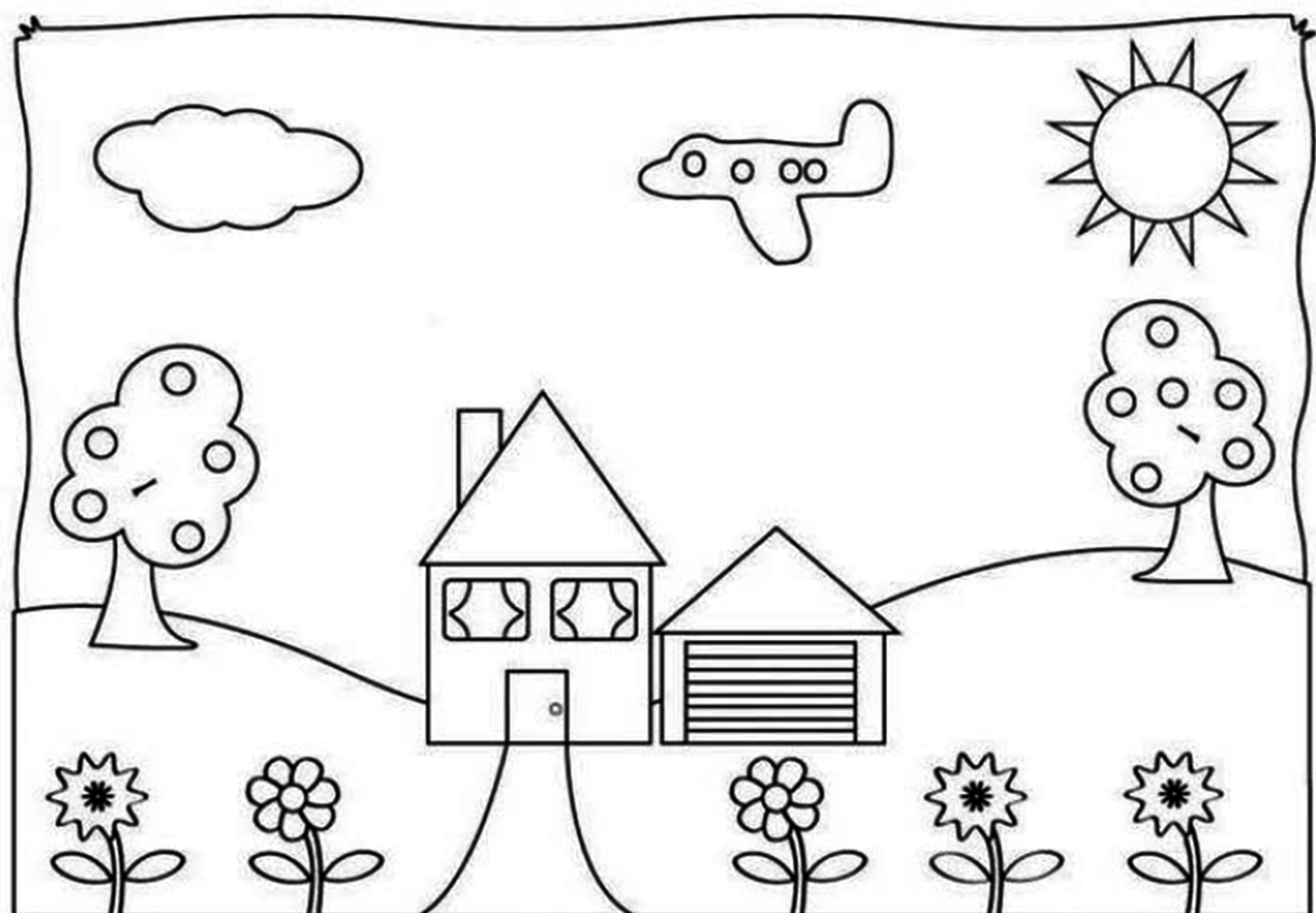
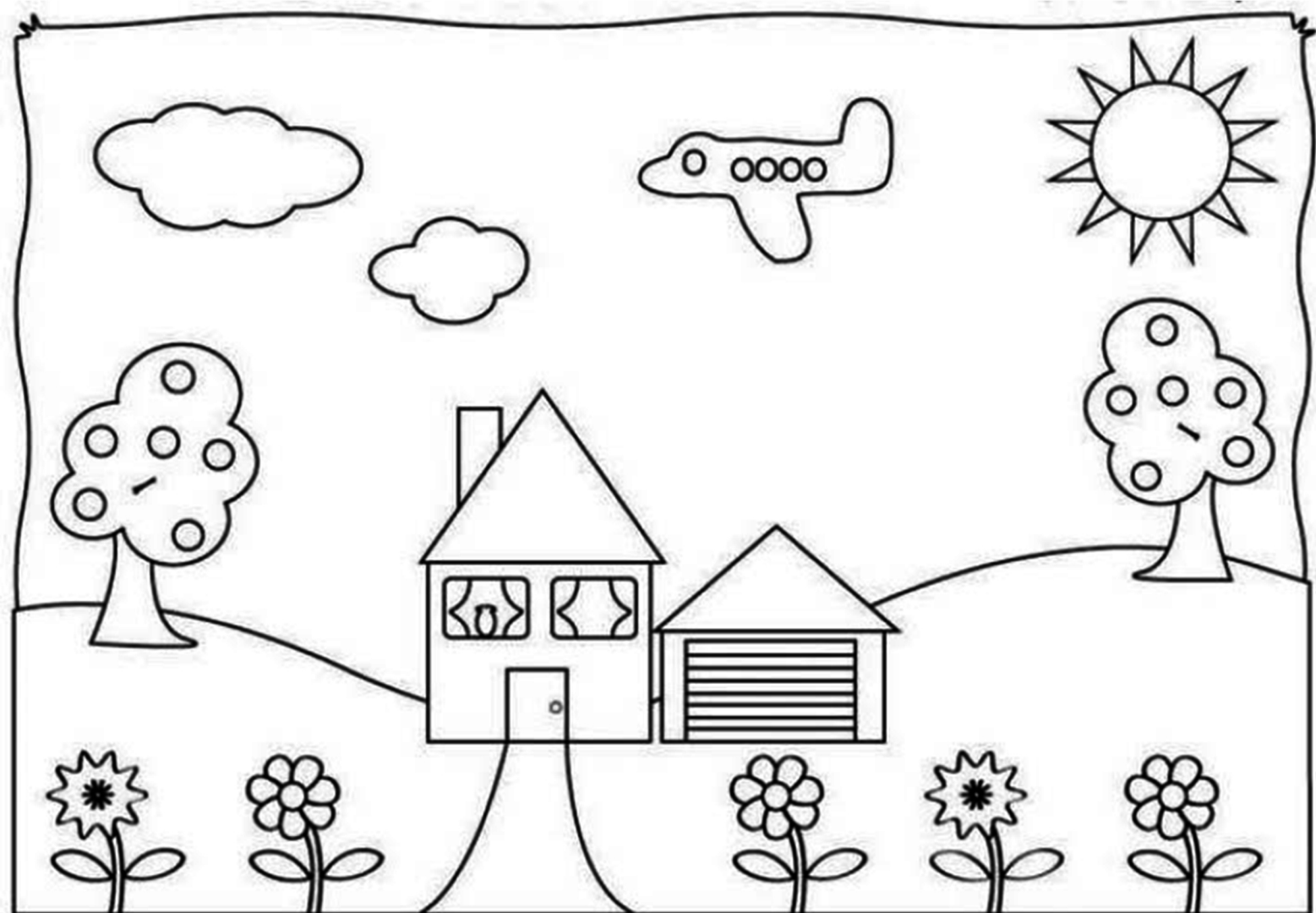

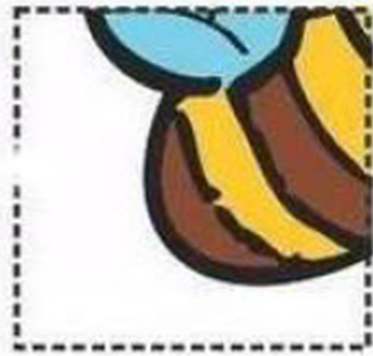
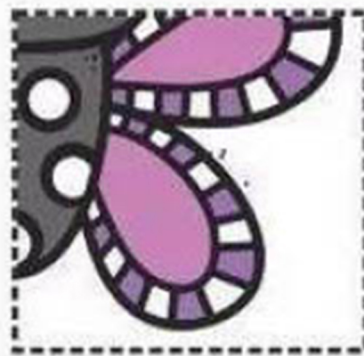
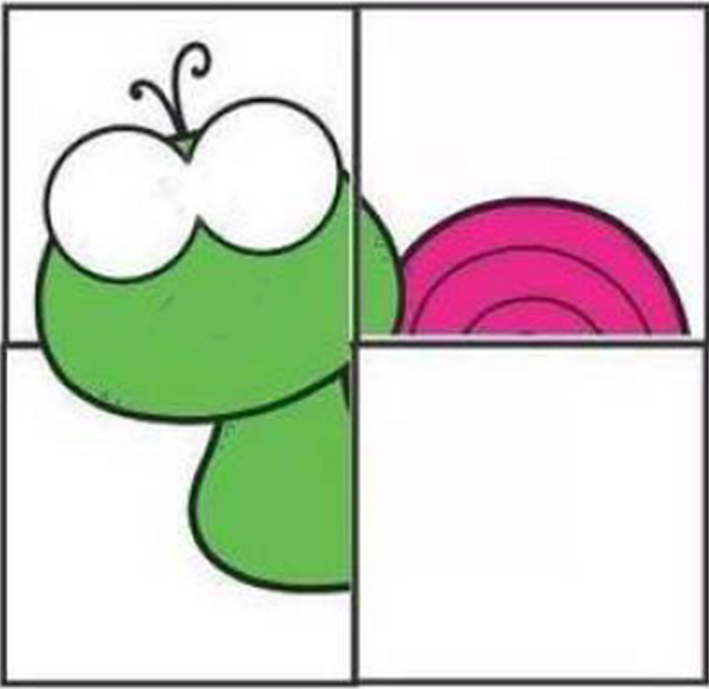
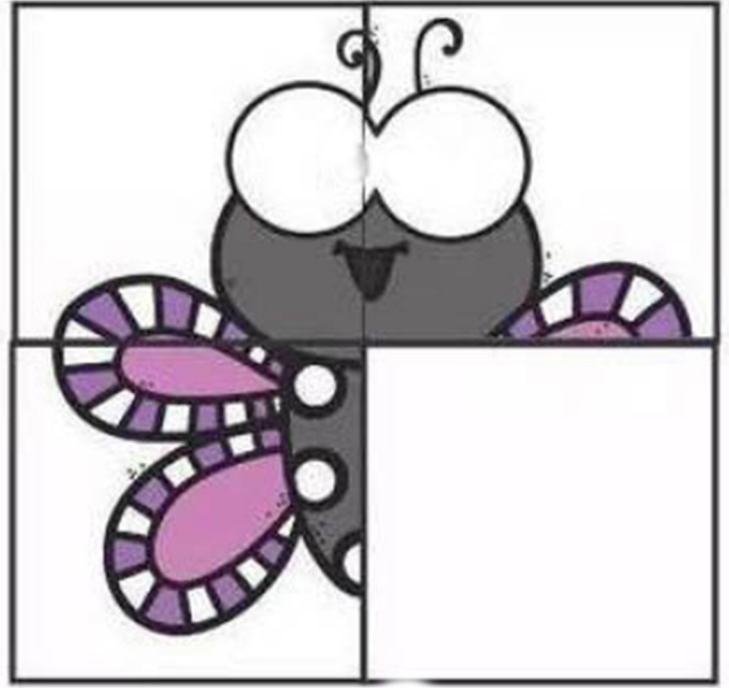
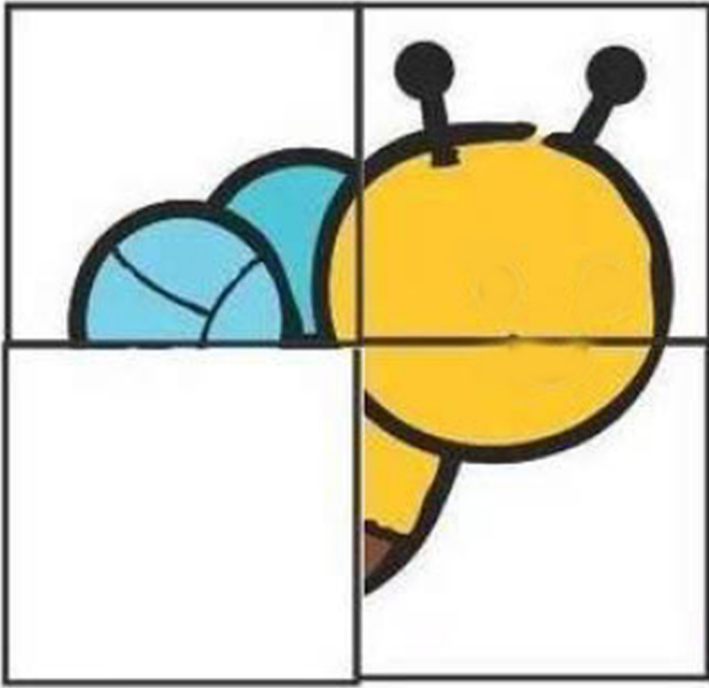

Complete the picture

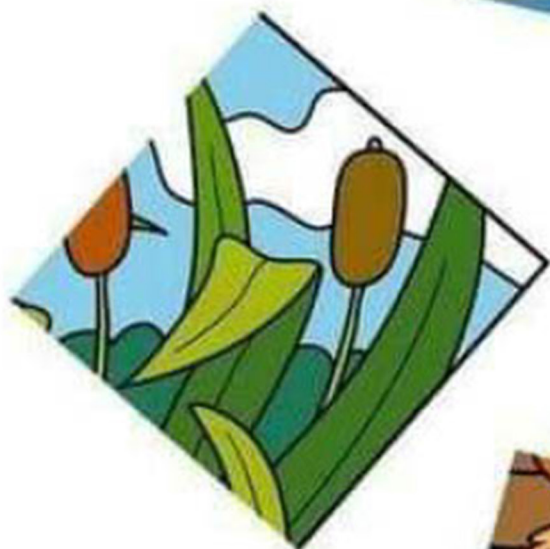
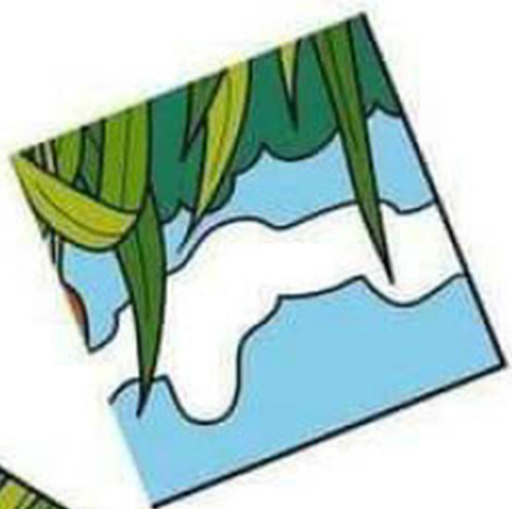
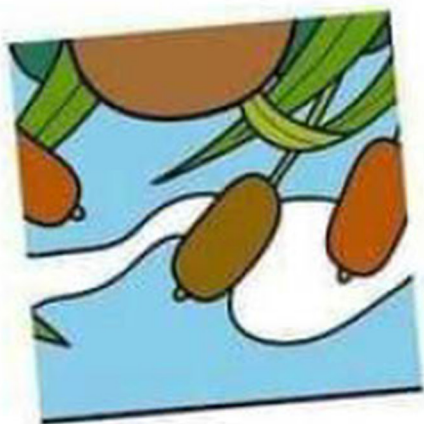

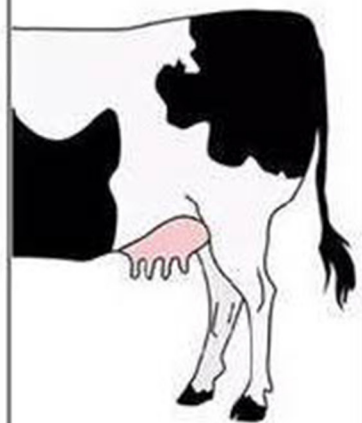
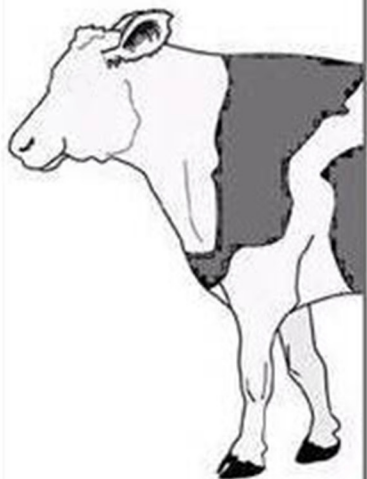
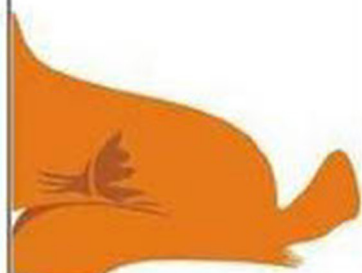

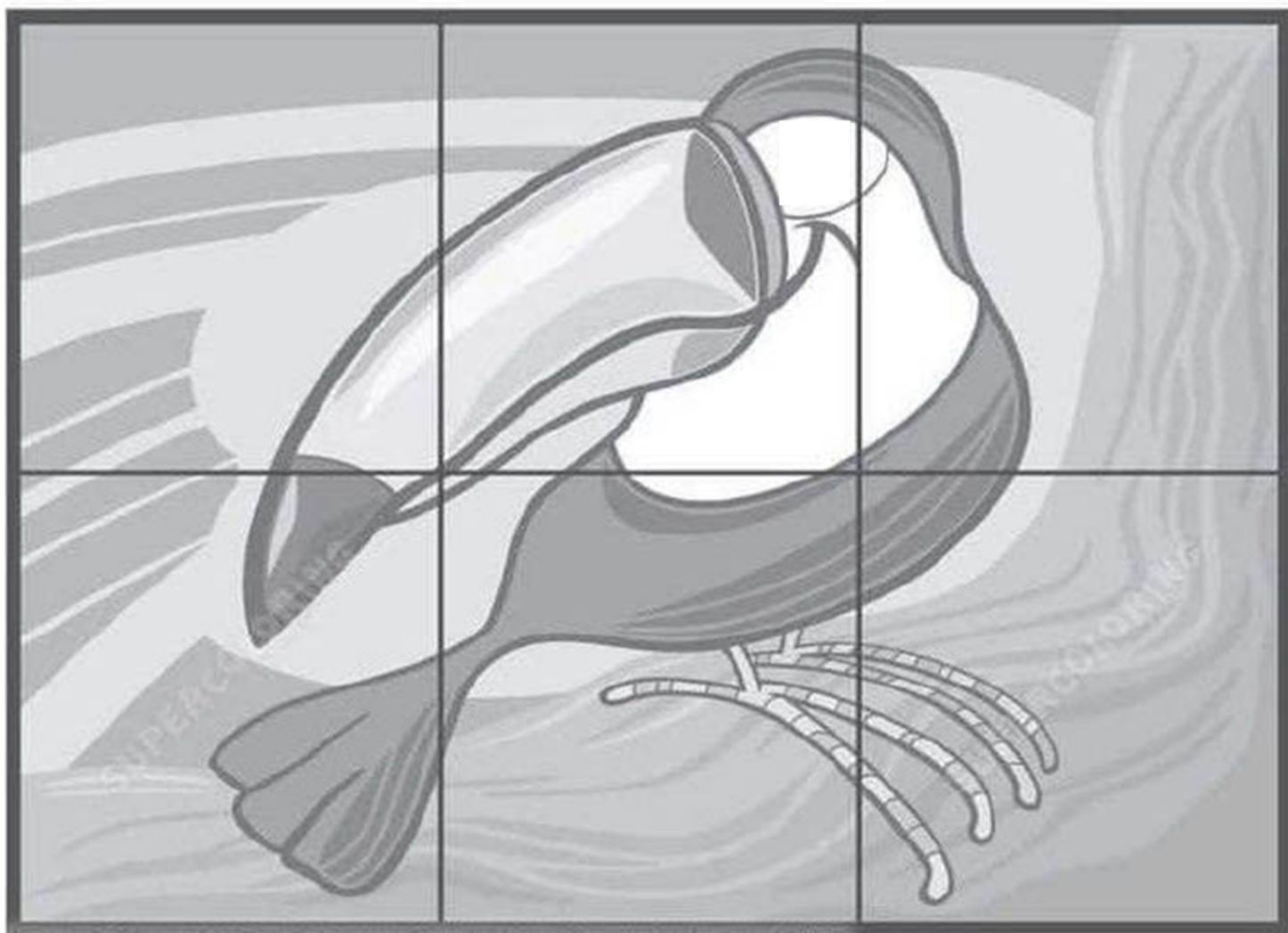
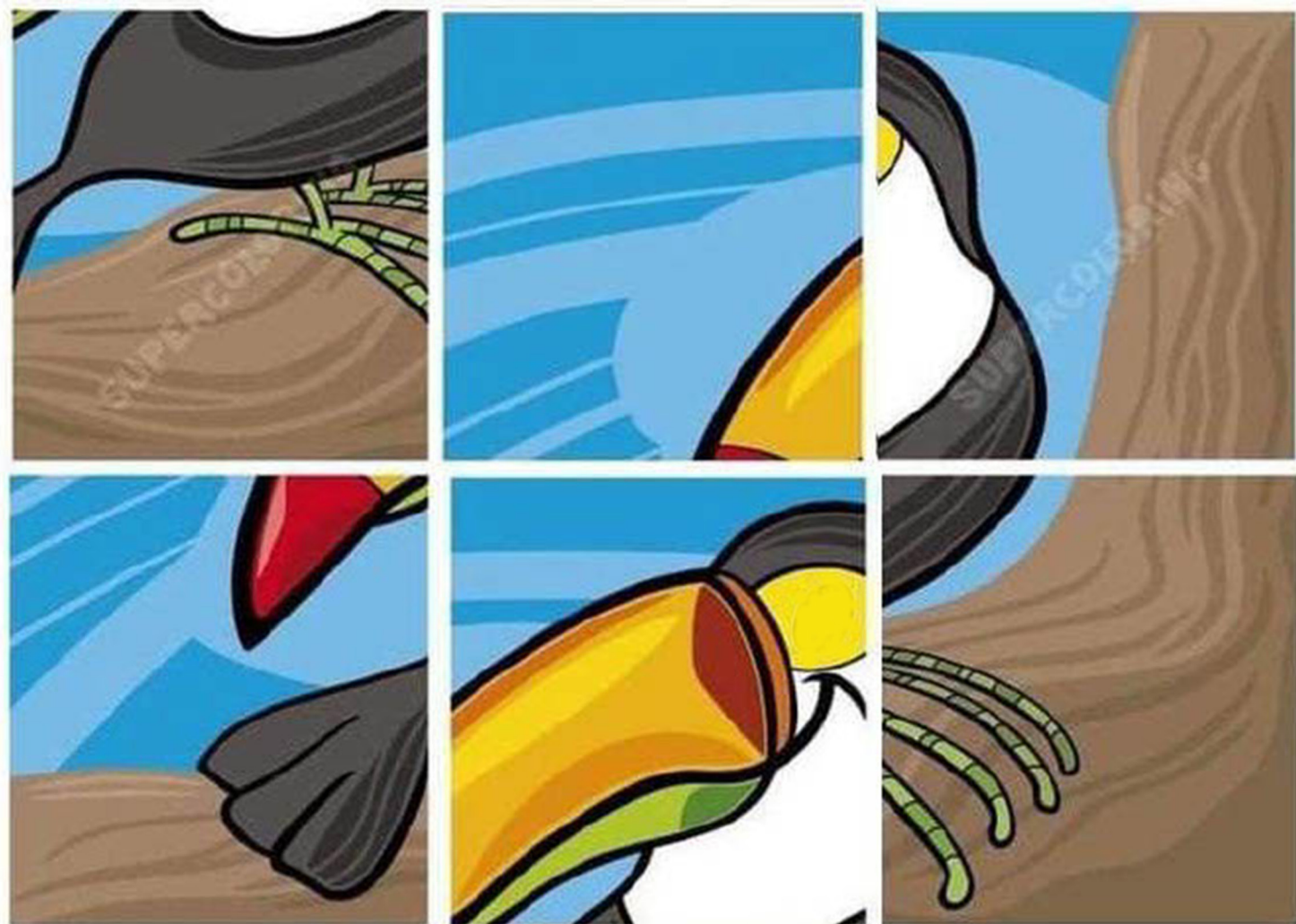

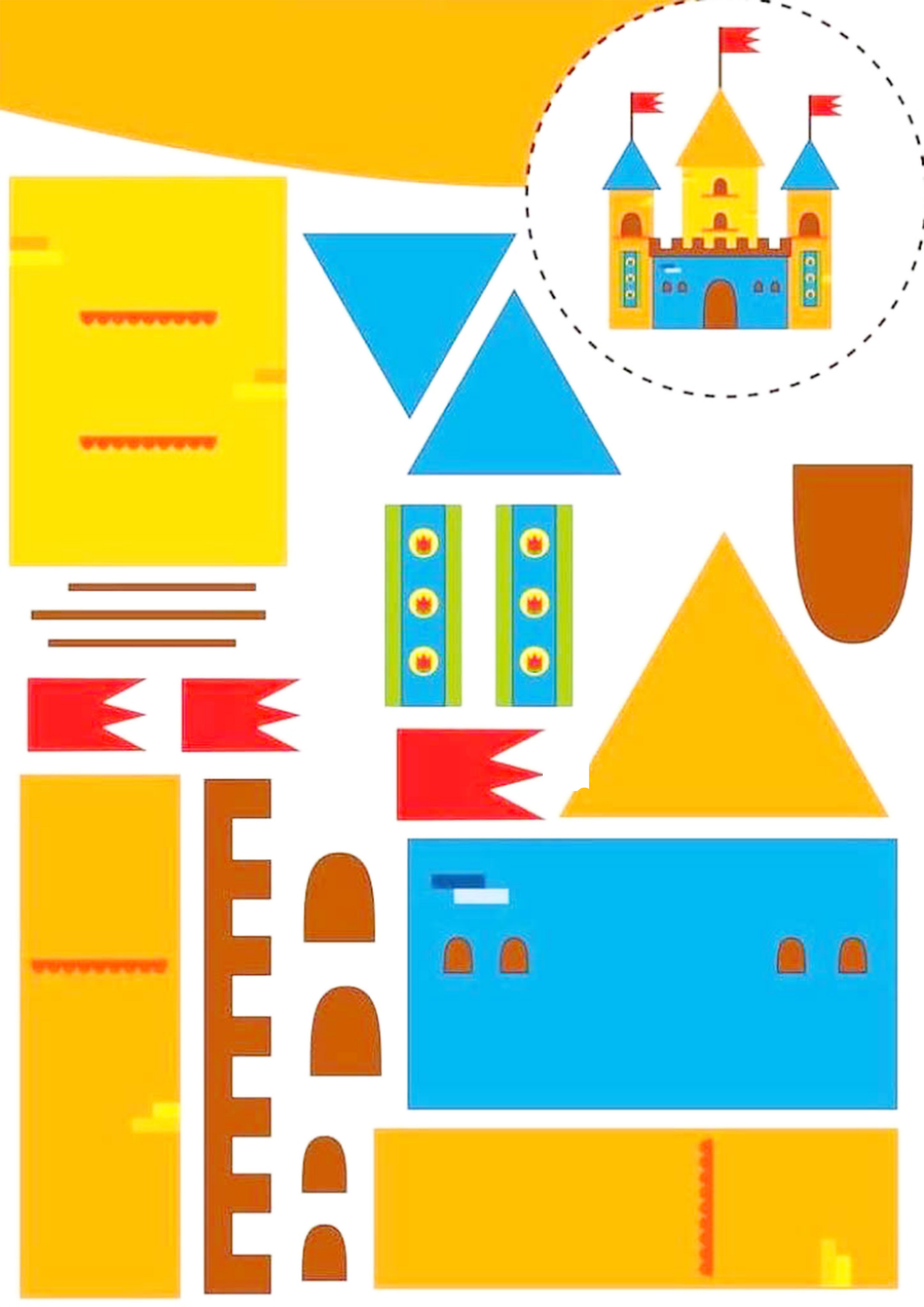



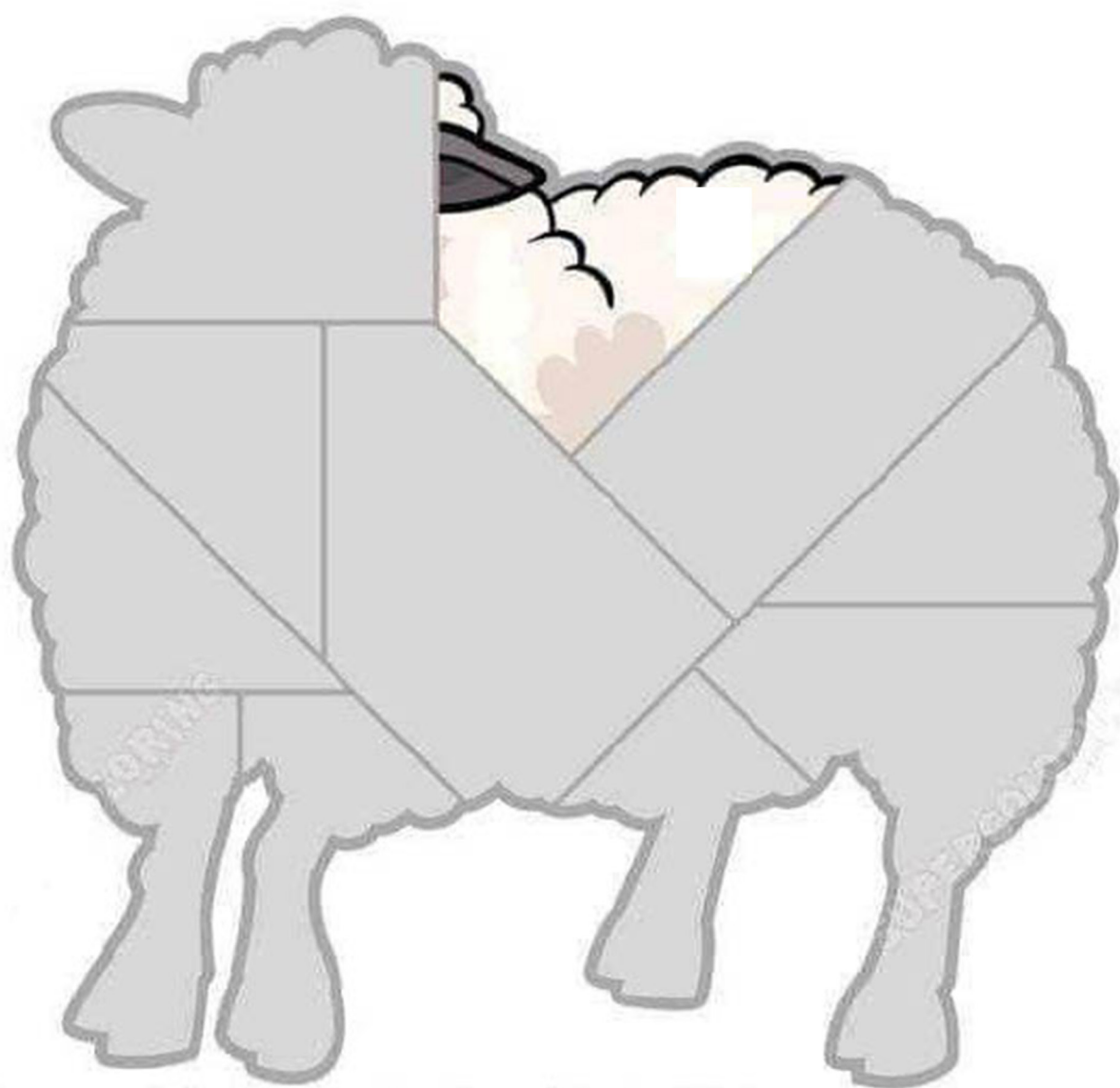
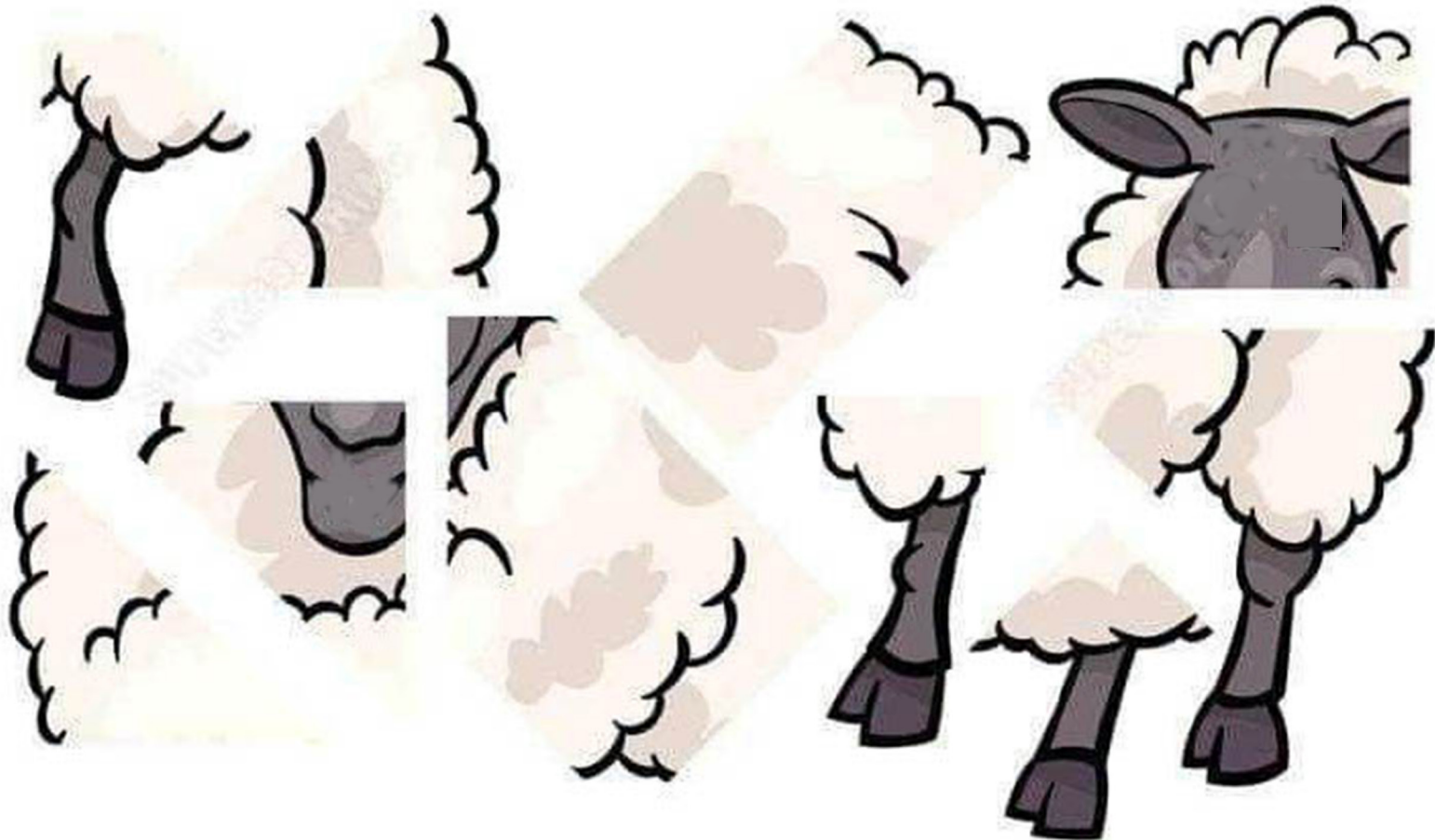



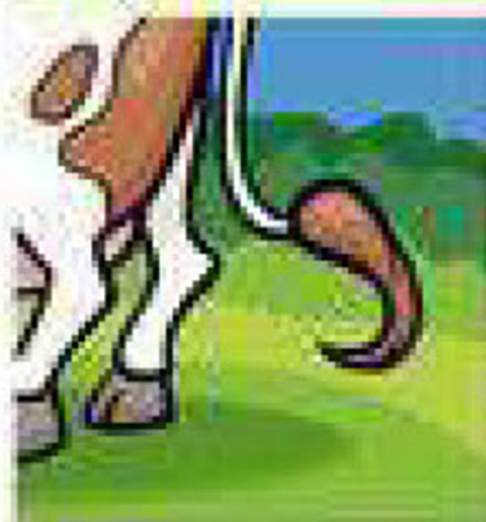

2

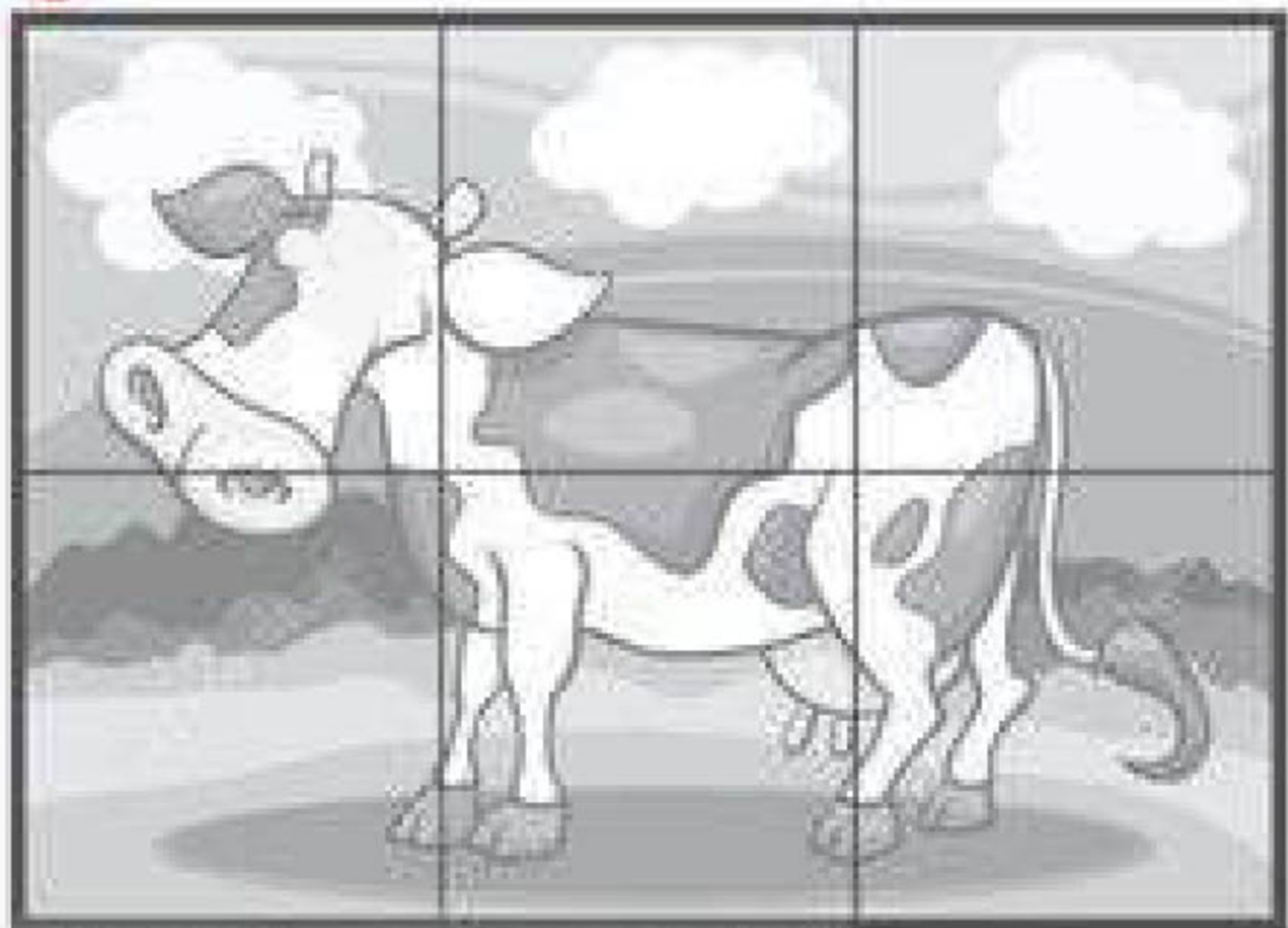



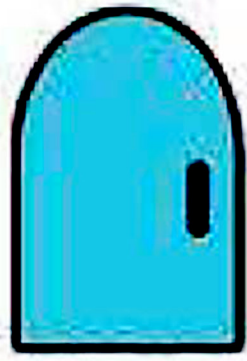
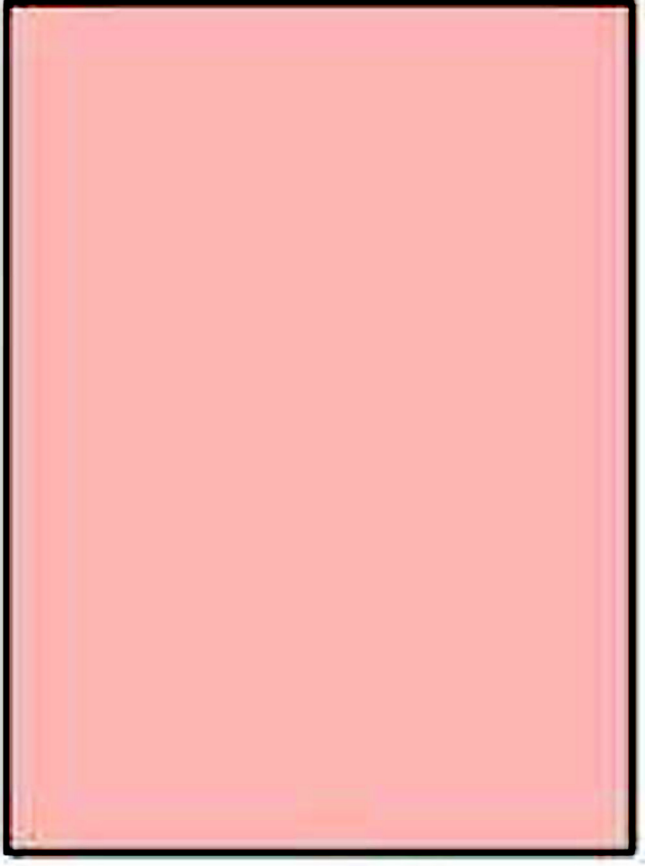
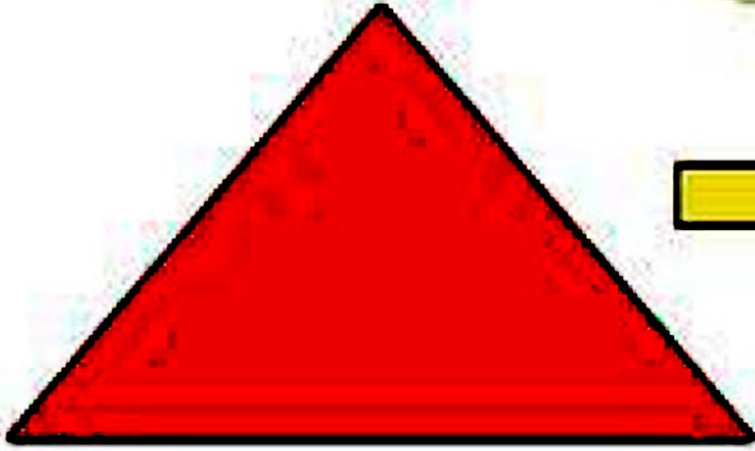

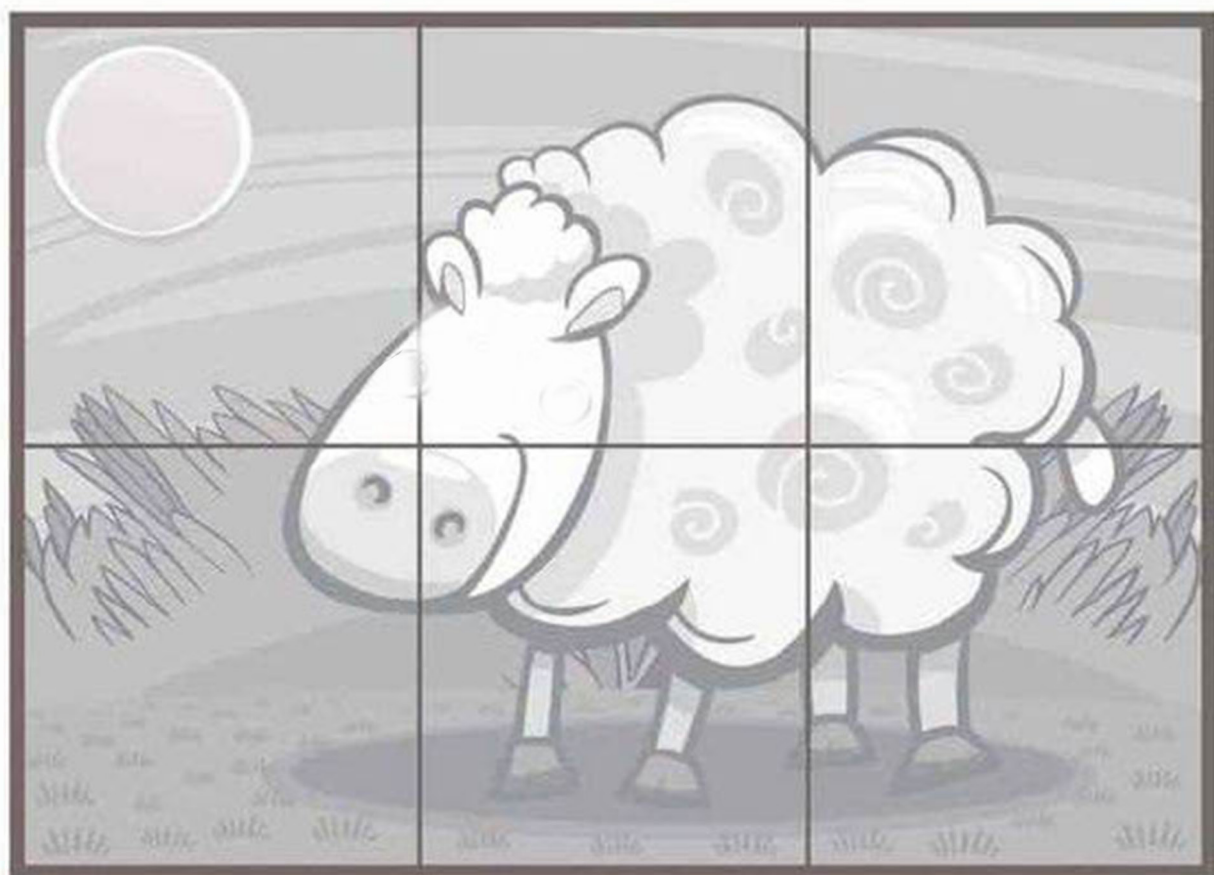

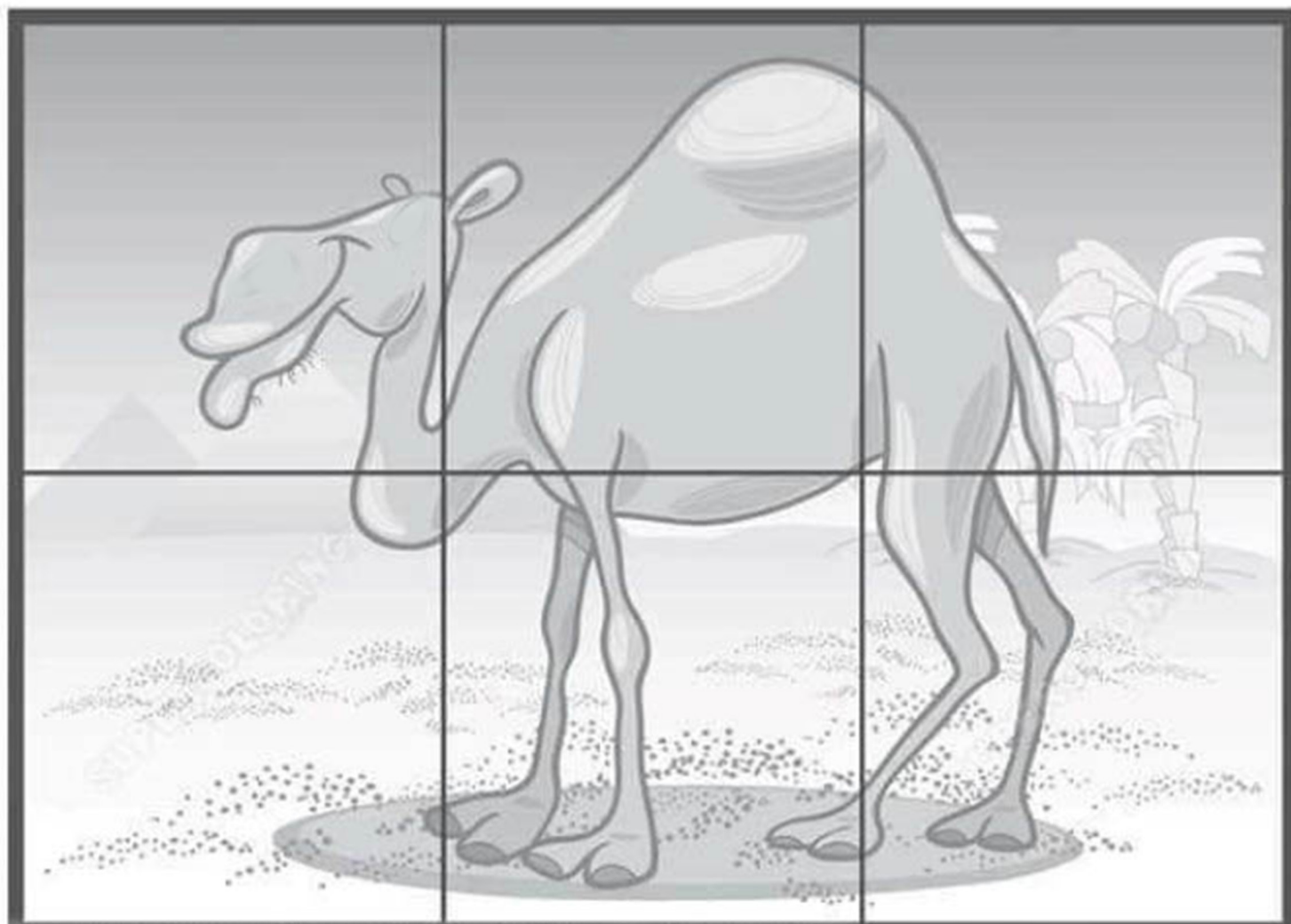
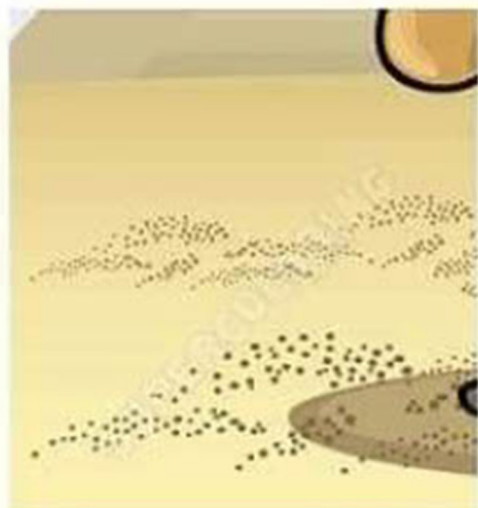

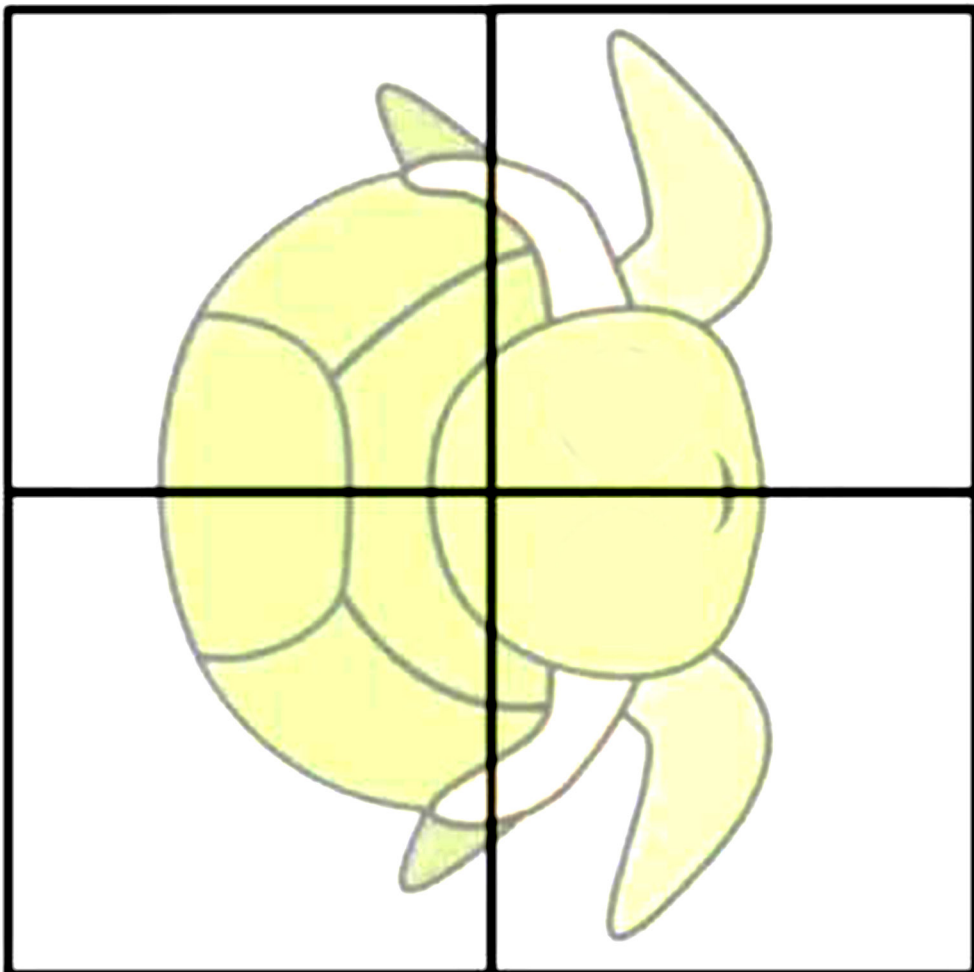
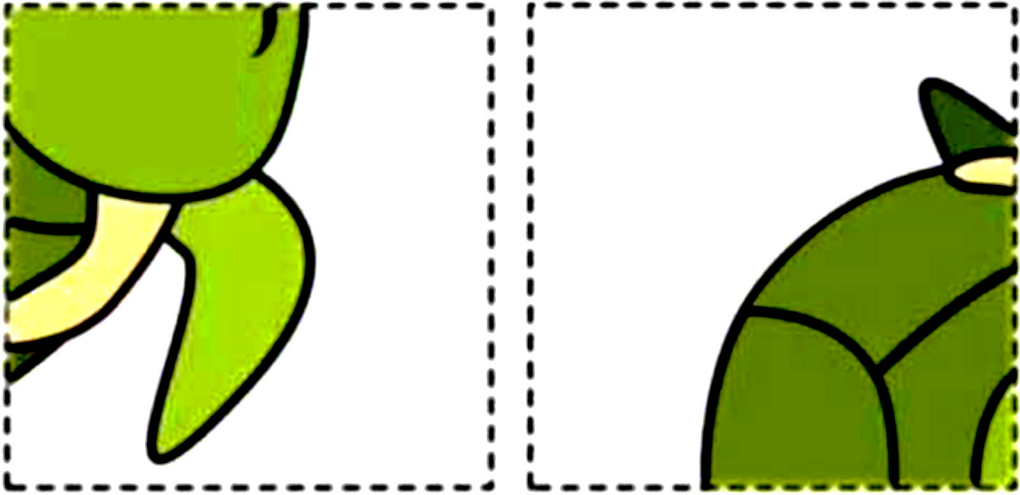
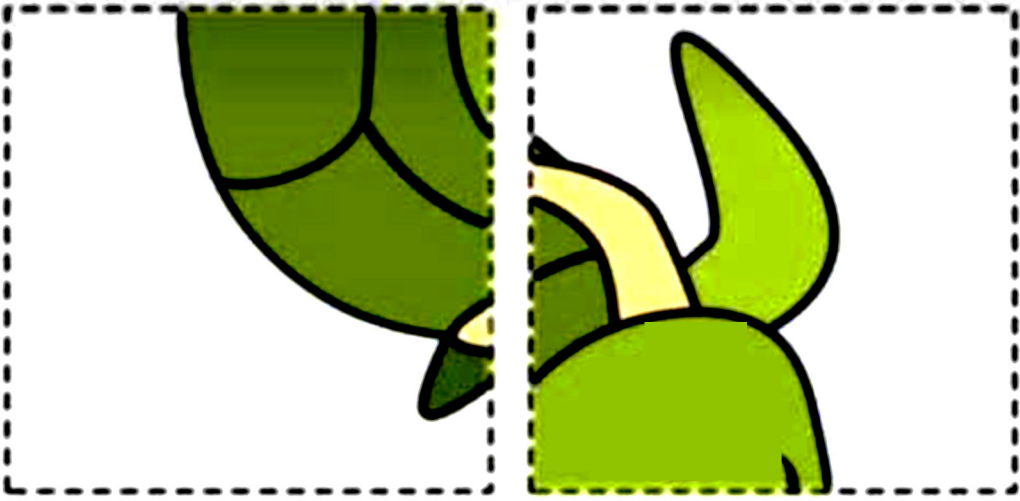

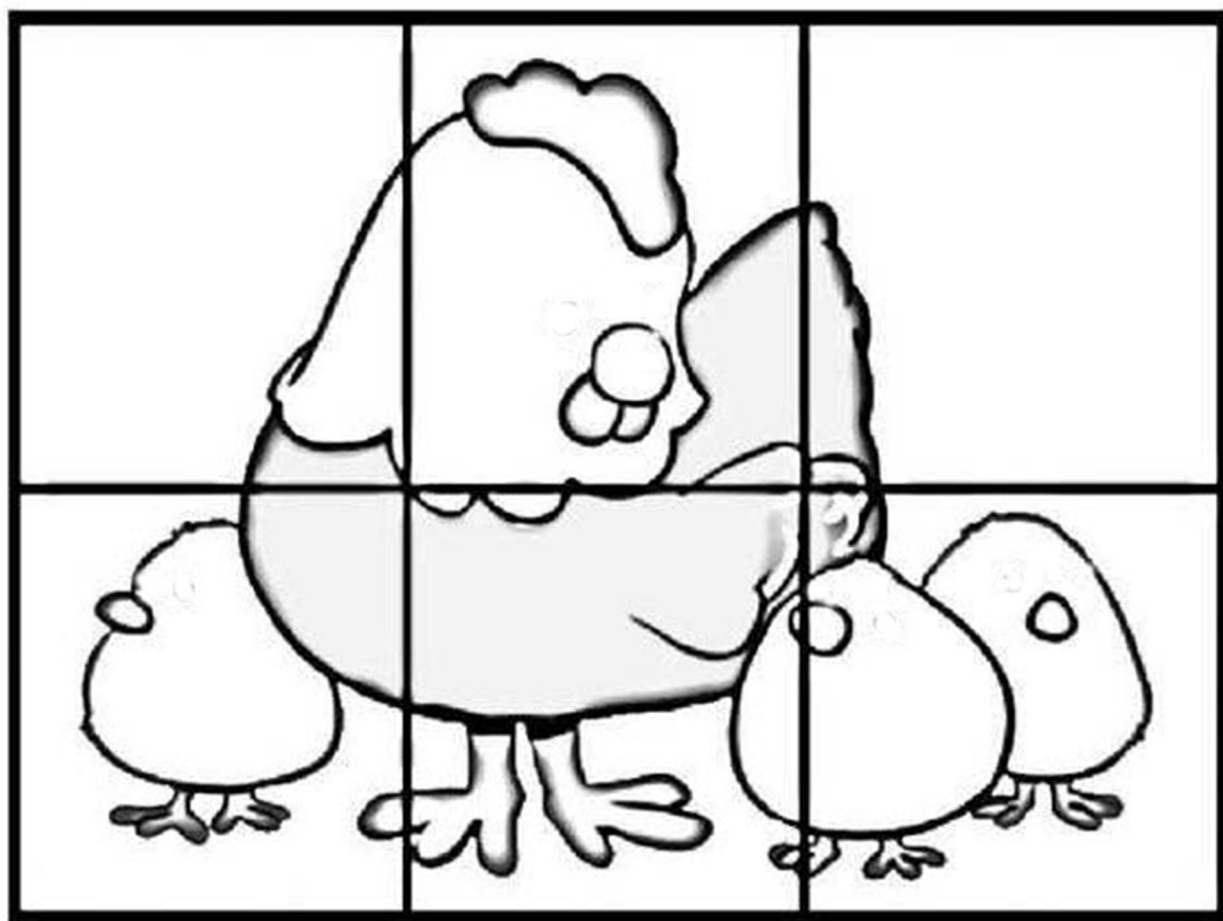
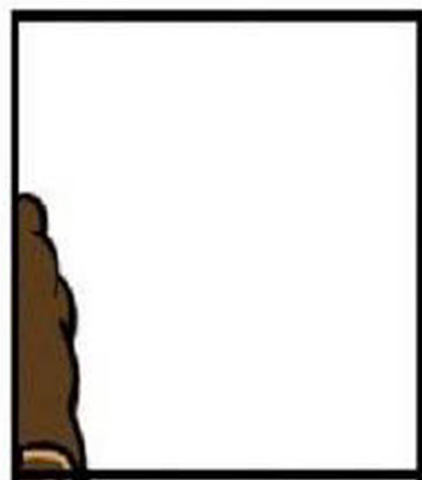
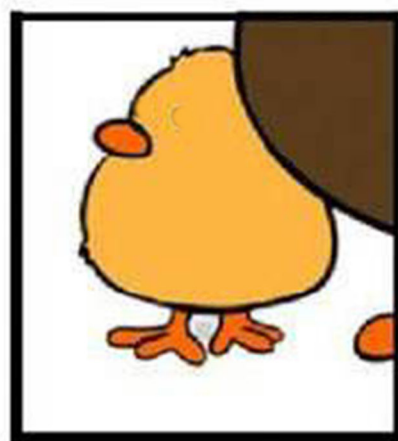
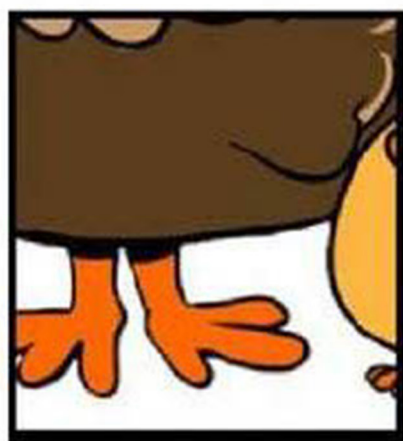
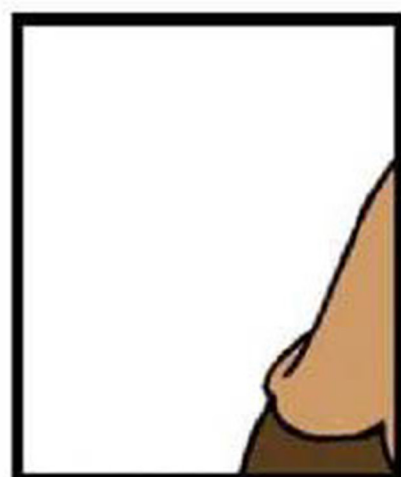

sea



crocodile



lake



camel



nest



Lion

desert



Fish



a duck



forest



Link the image as appropriate

whale



swamp



Ocean



pigeon



banana



Beehive



herb



Fish



grains



carrot



cheese



tuna



rabbit



cat



monkey



bee



sheep



dolphin



chicken



mouse





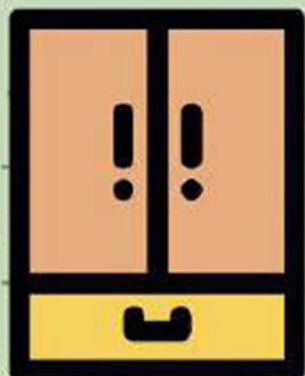
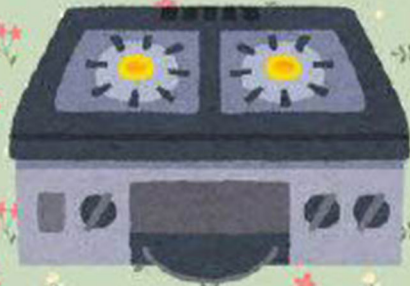

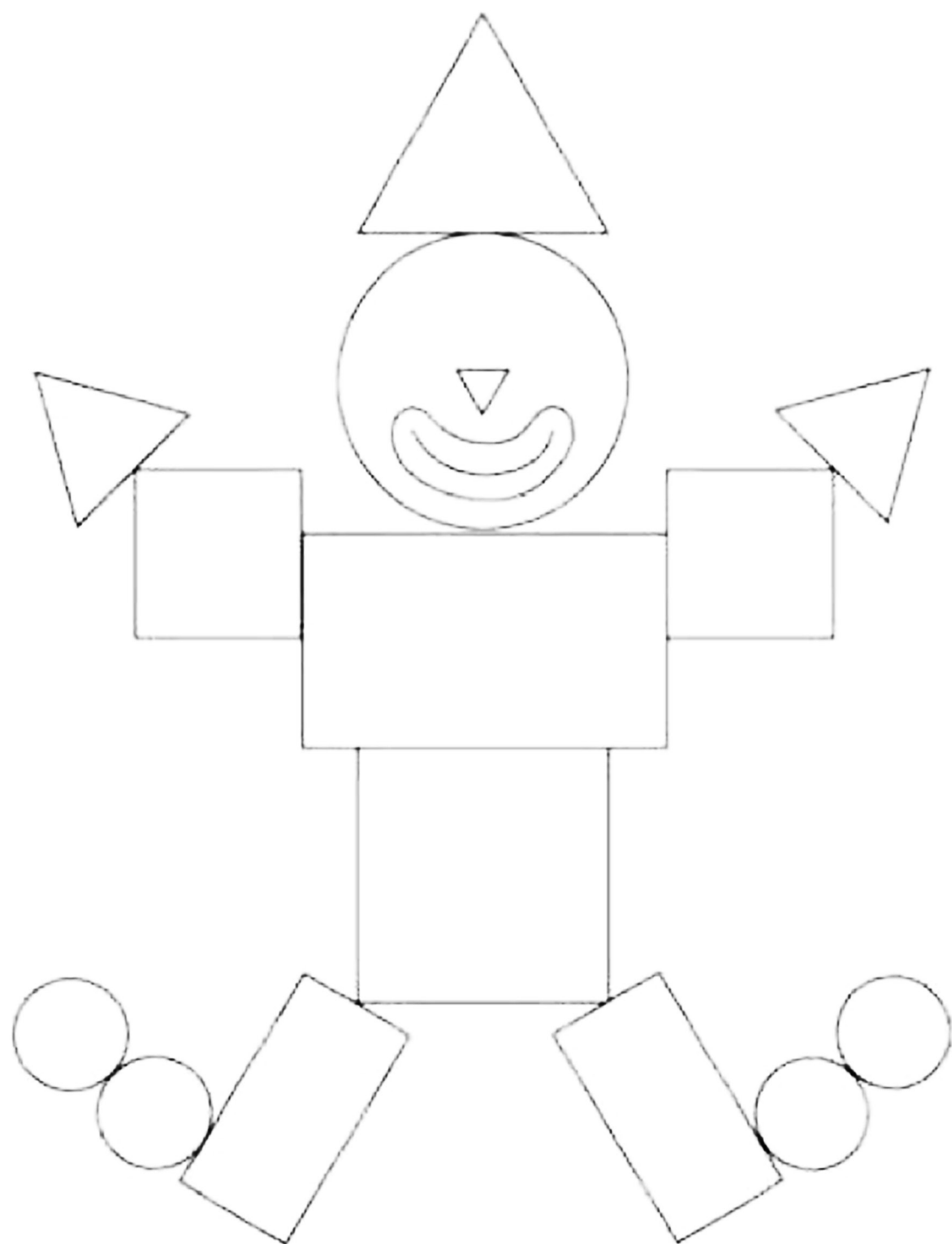

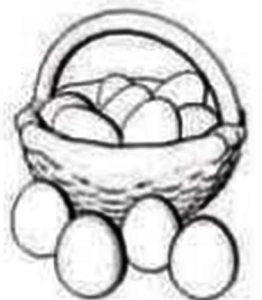
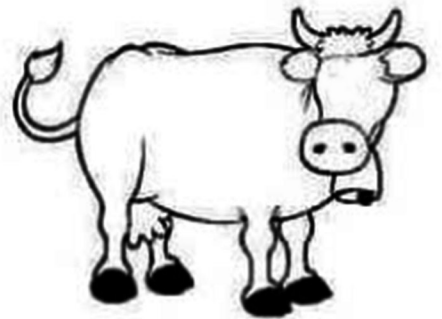
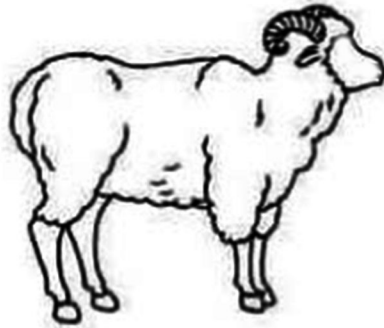
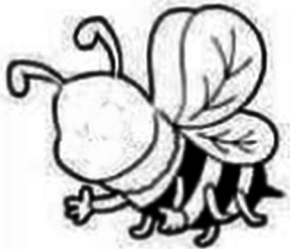
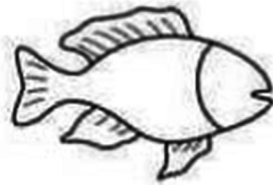
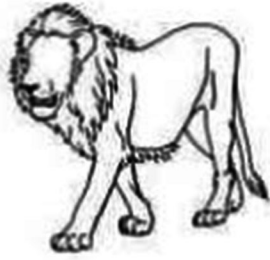

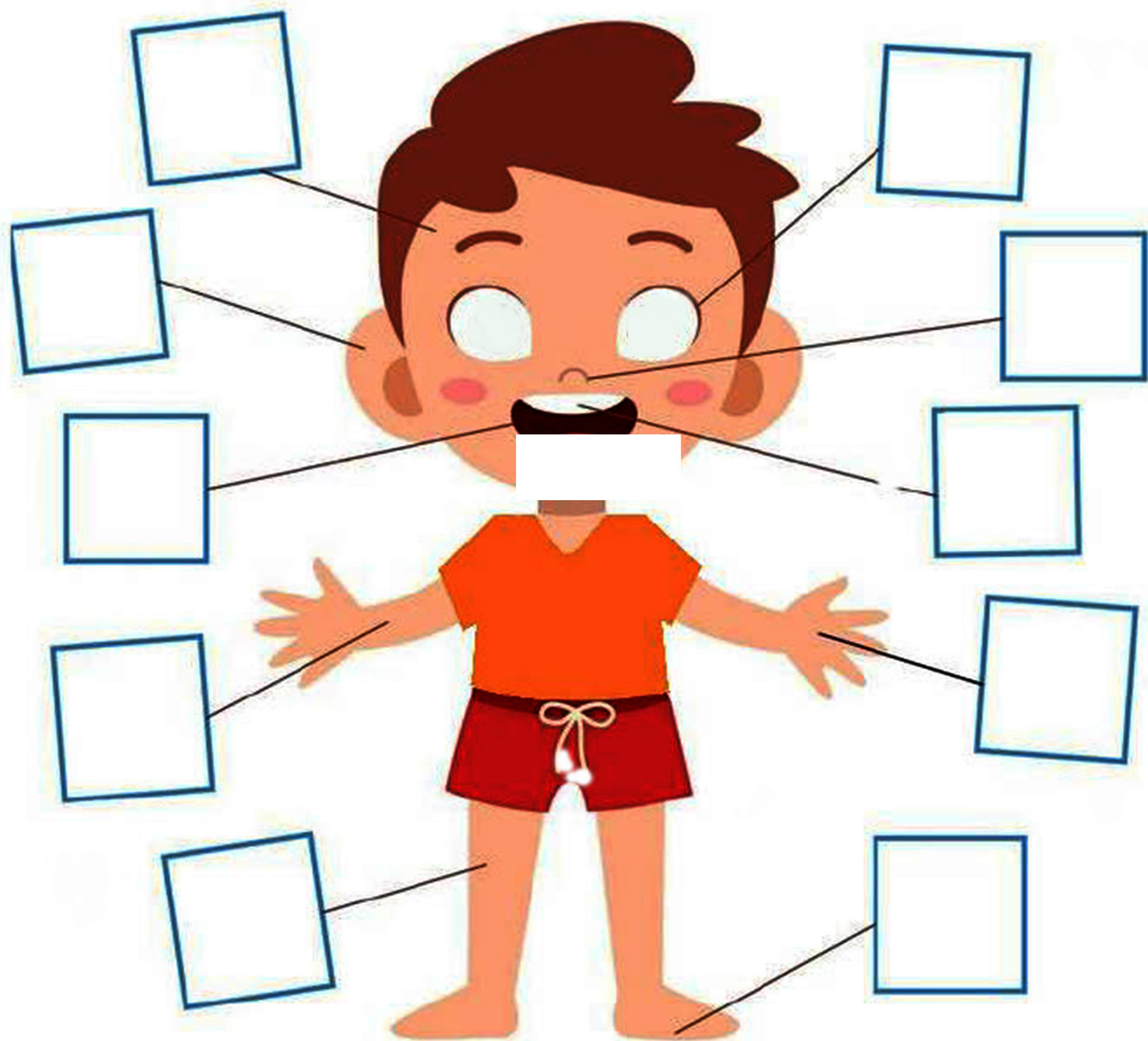

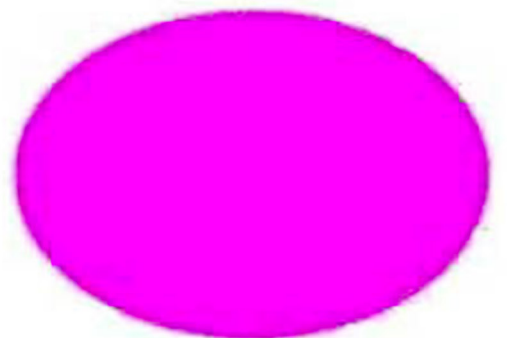
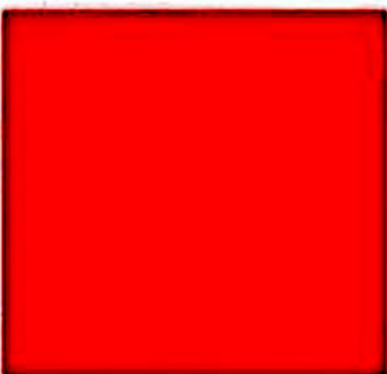
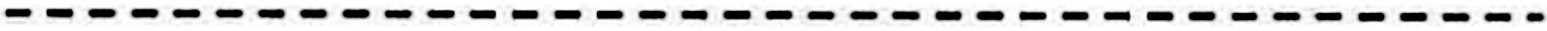
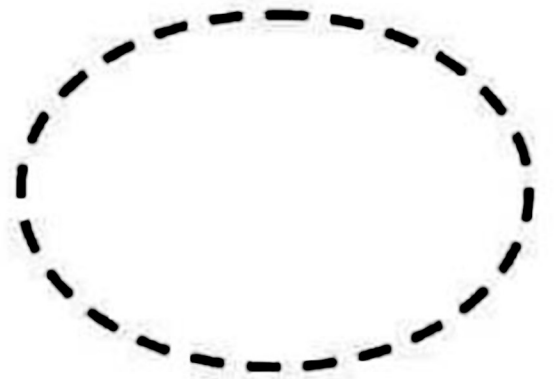
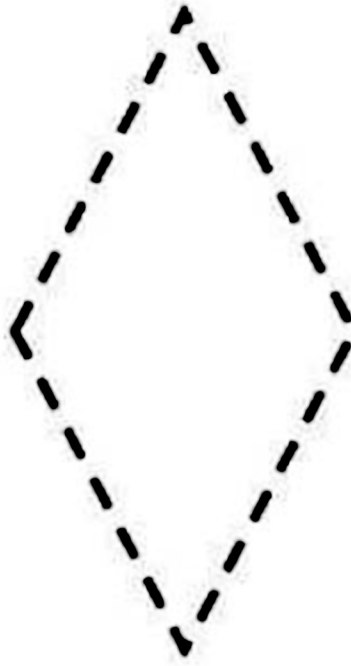
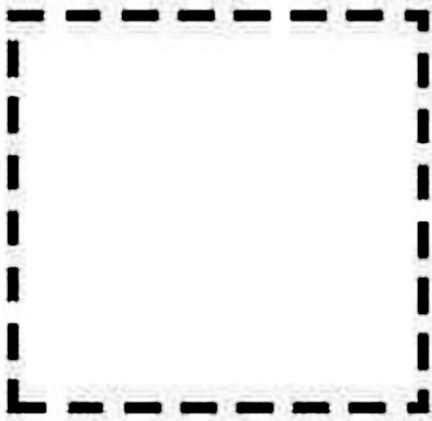
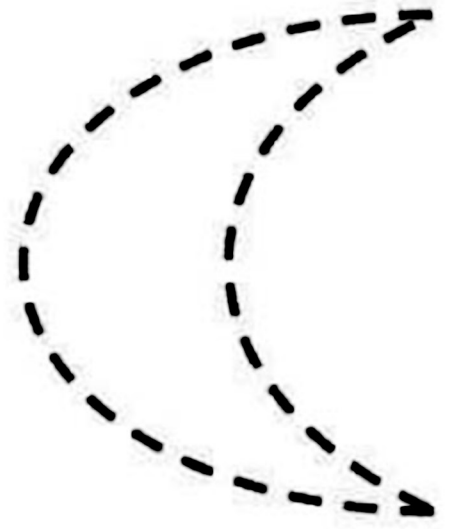
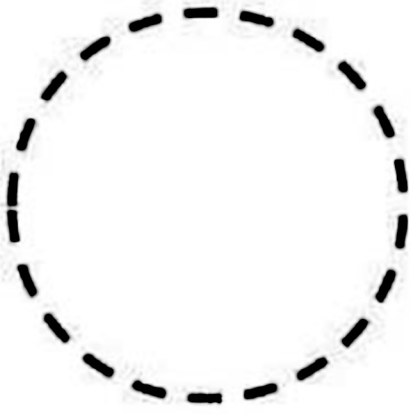



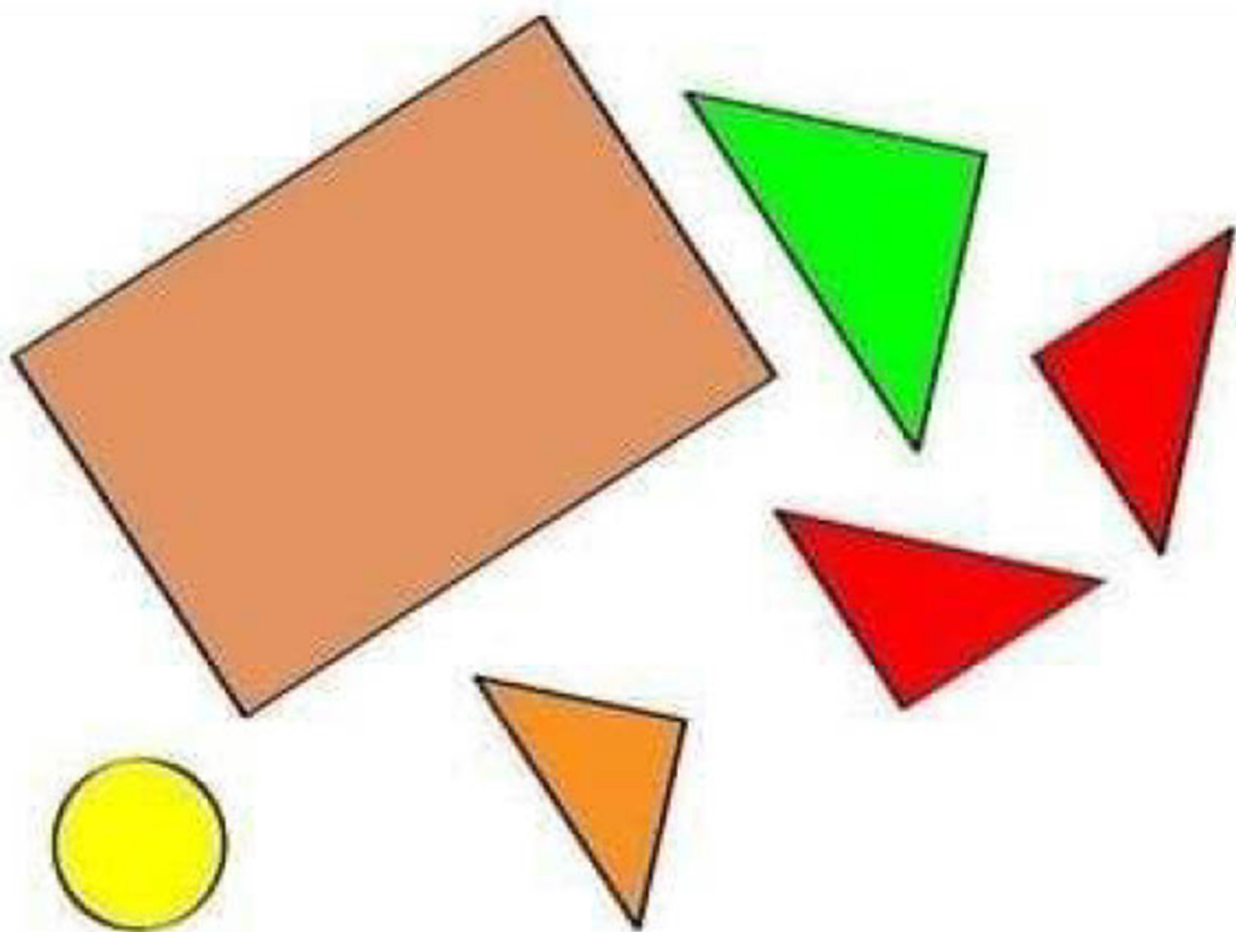
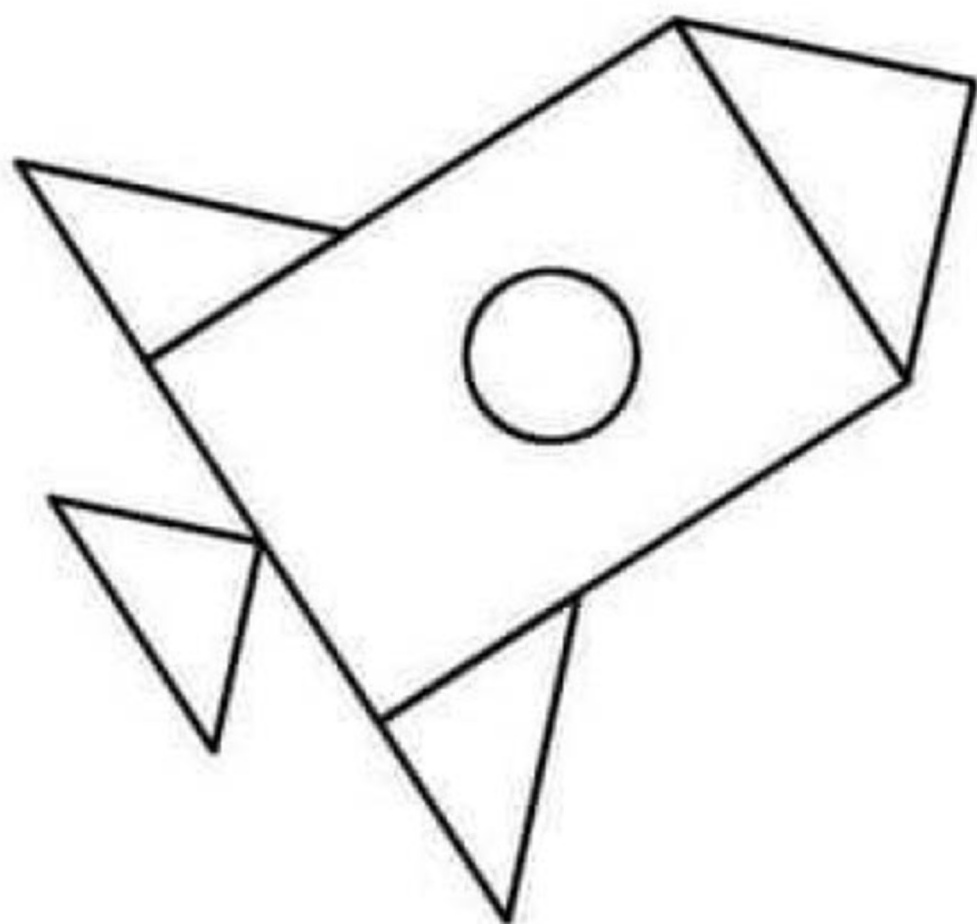

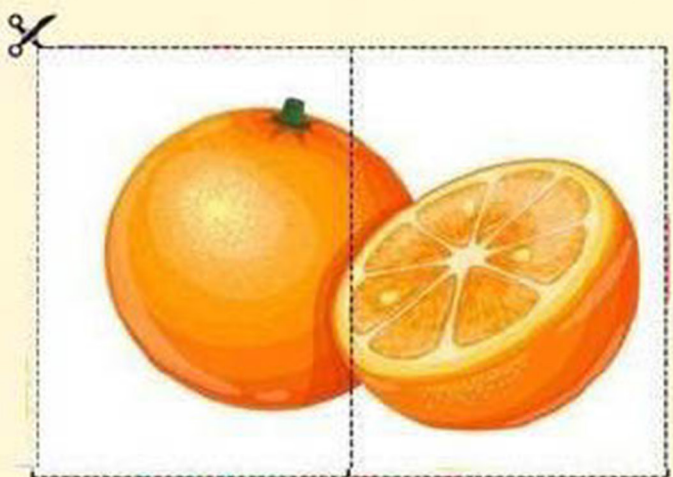
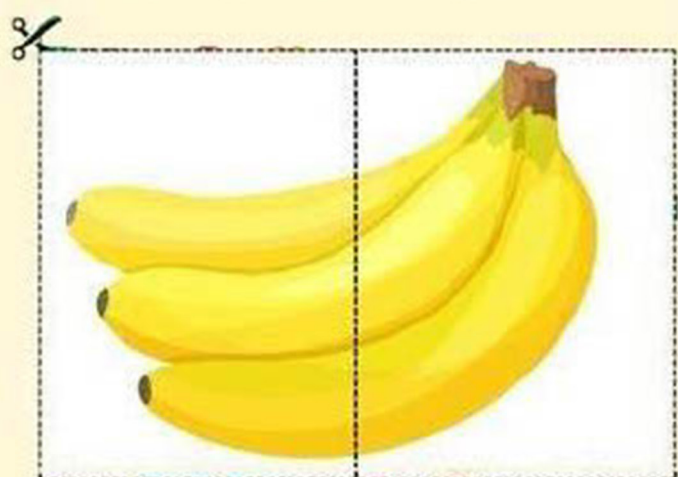
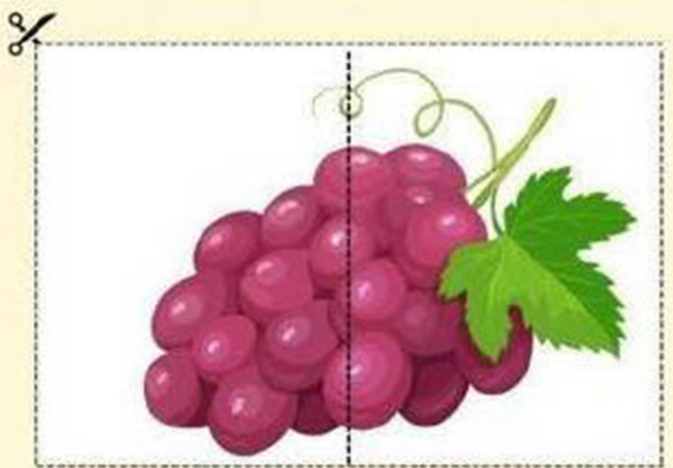
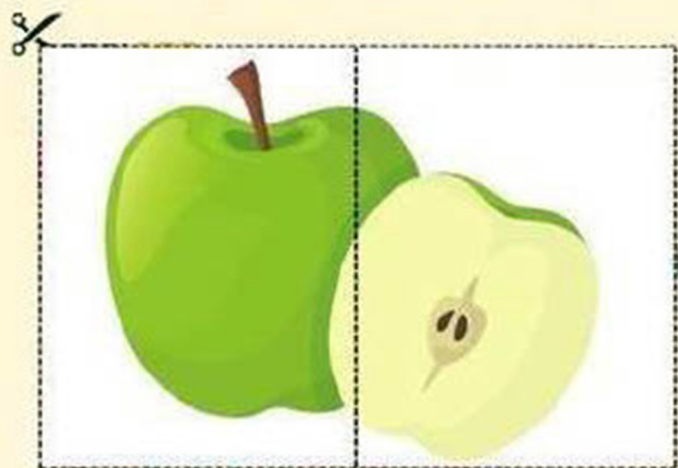
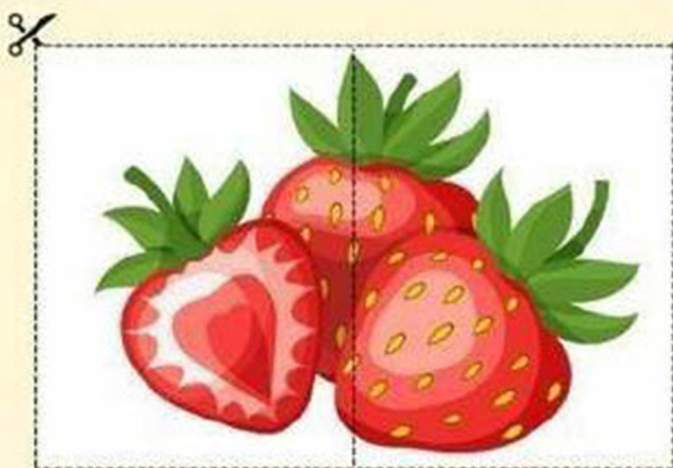
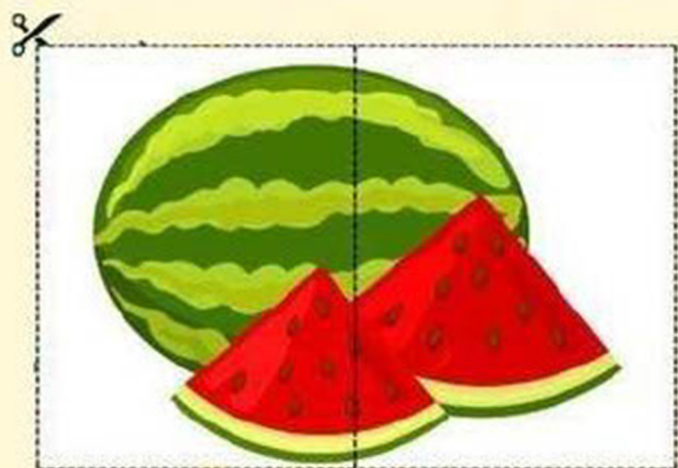
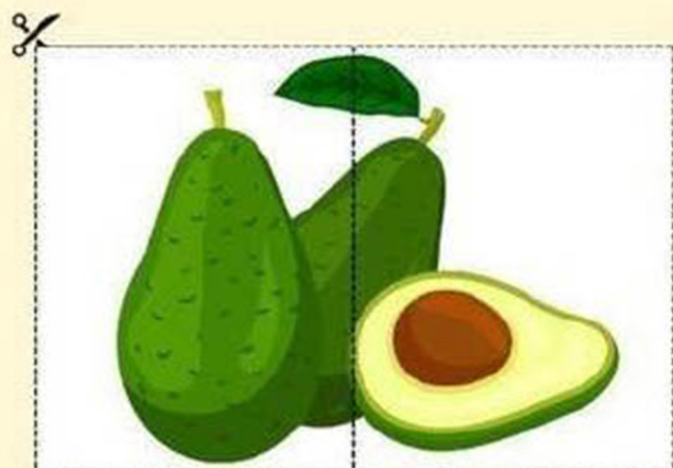
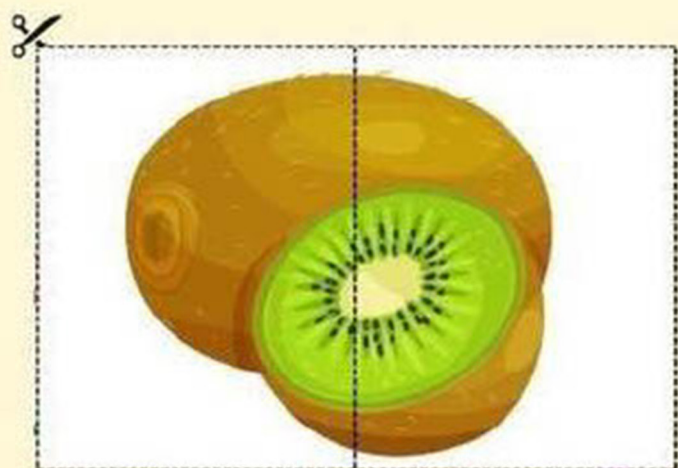

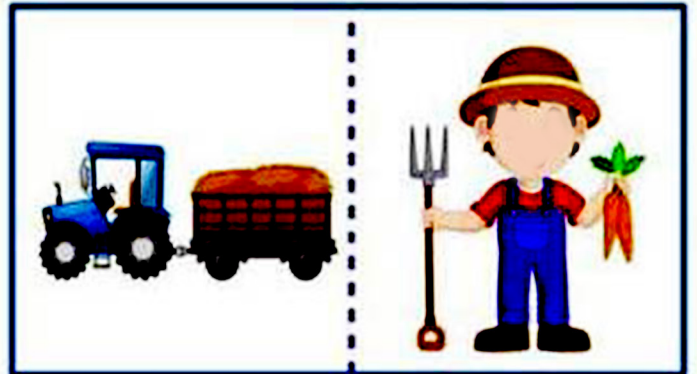

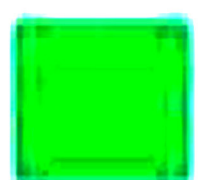
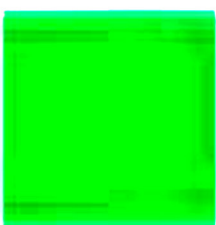
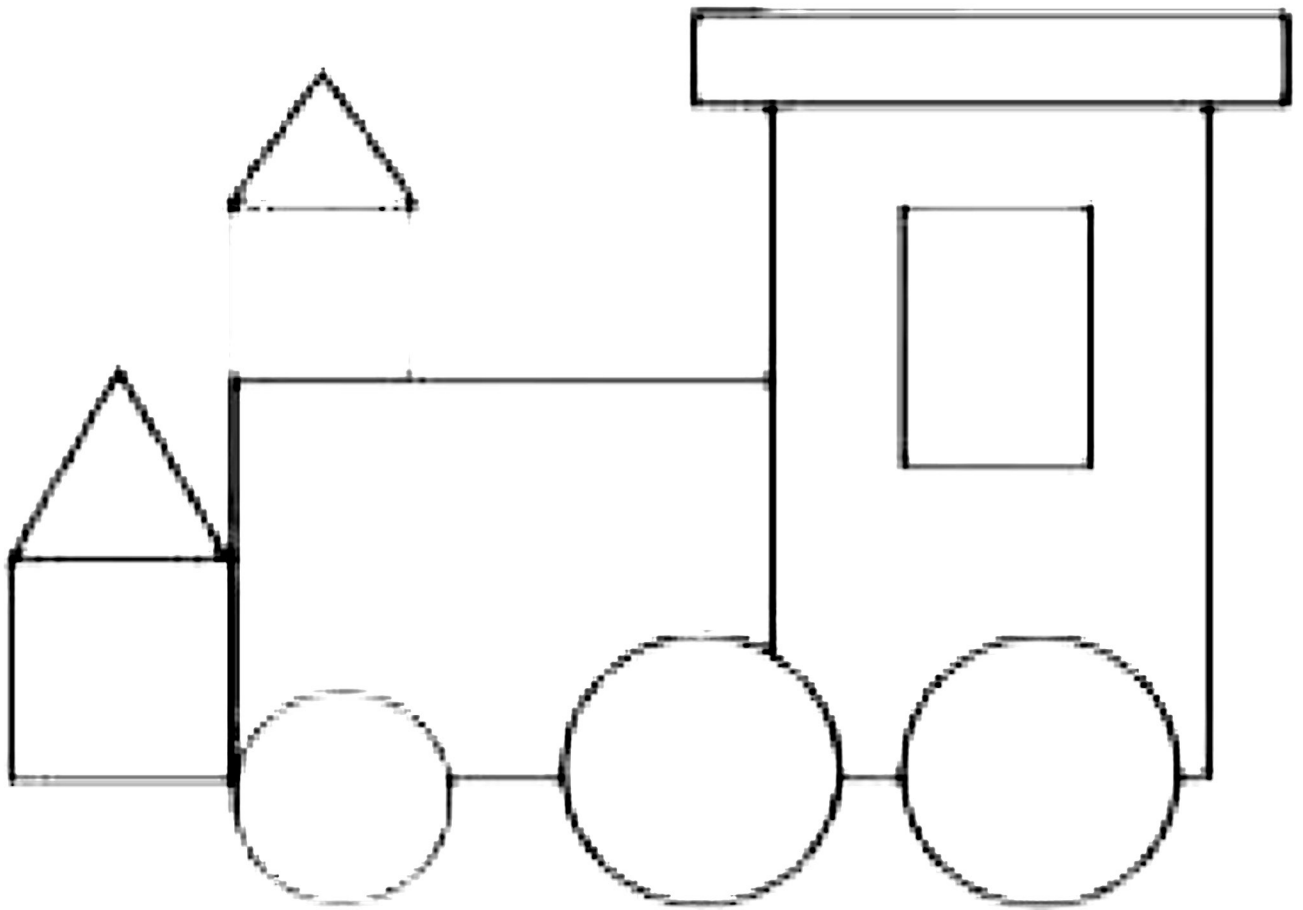

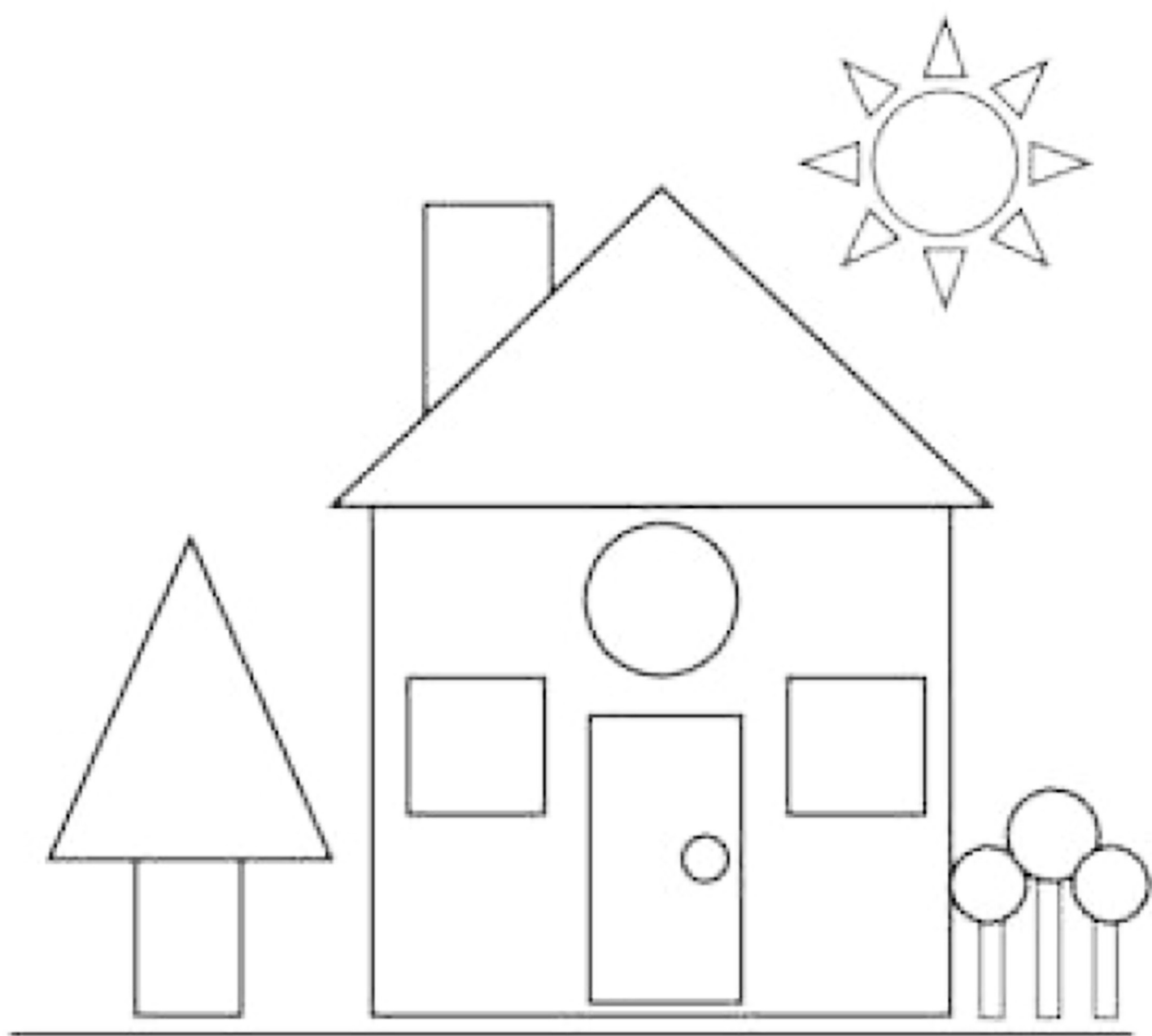

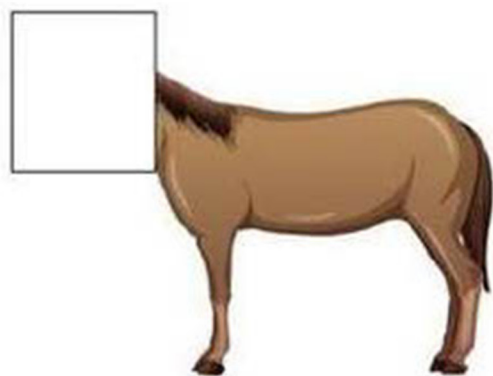
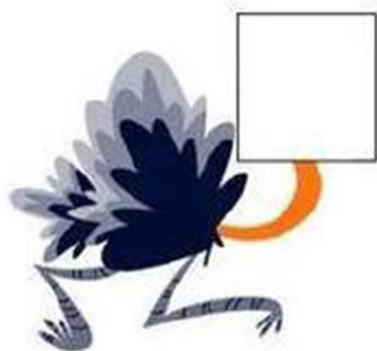
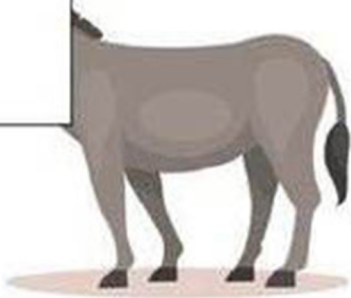
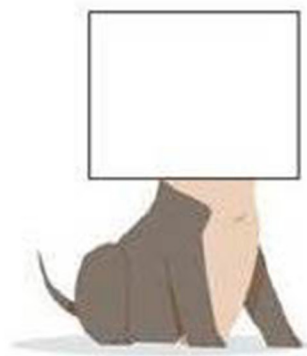
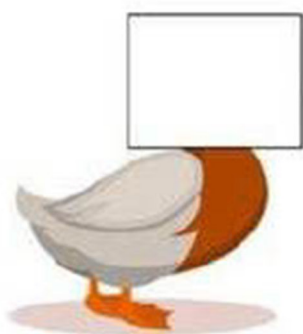
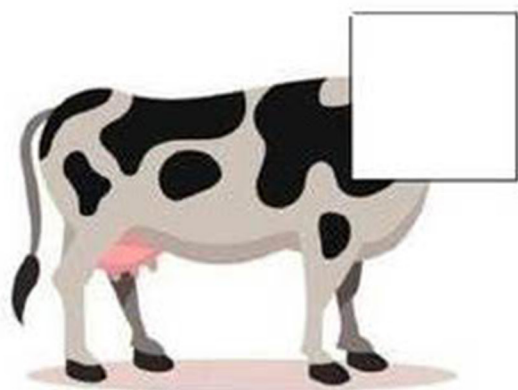

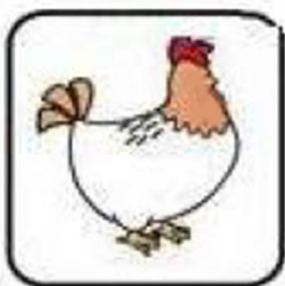





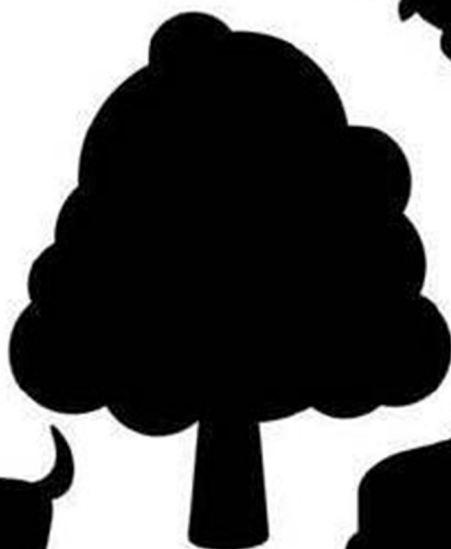
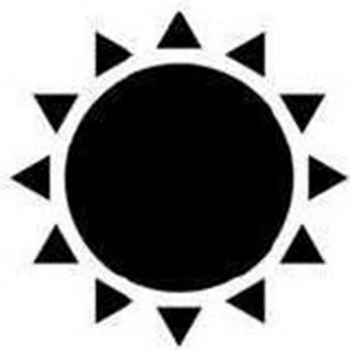

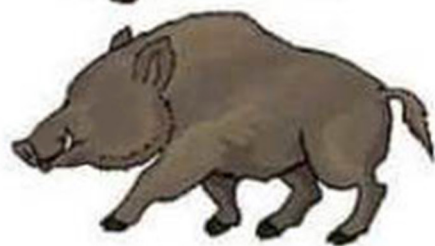

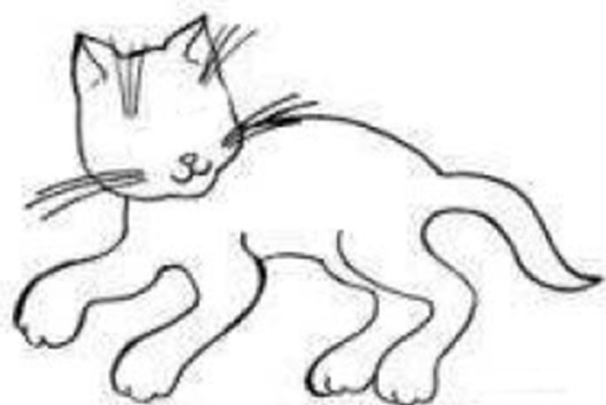

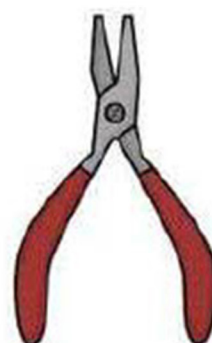
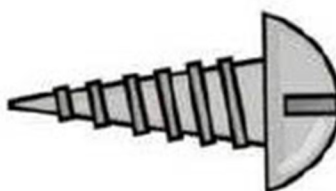
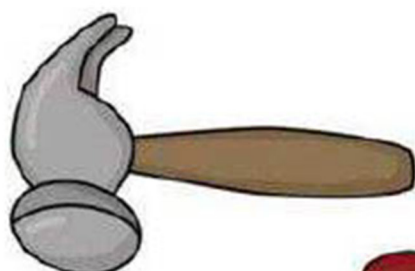
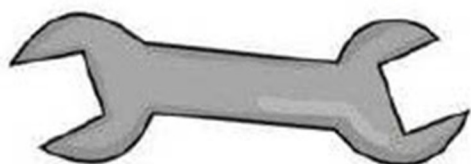
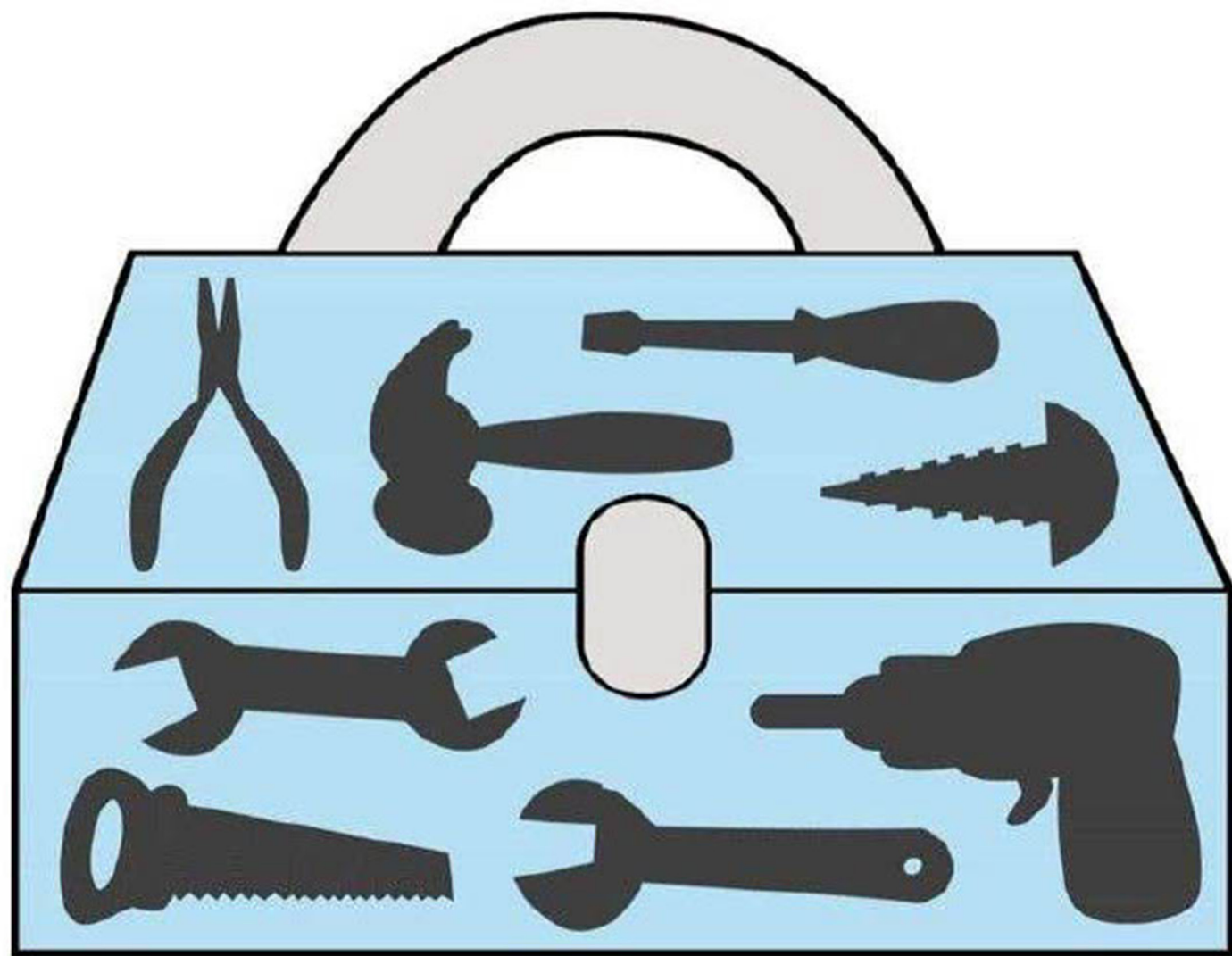



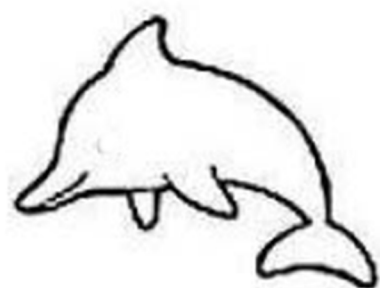
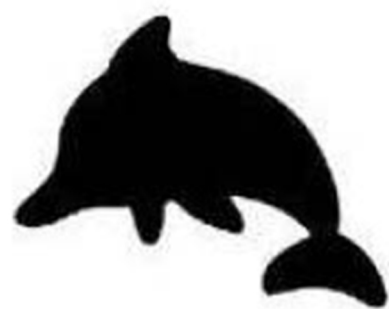

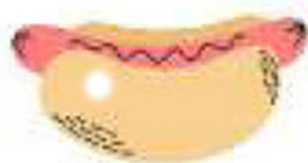











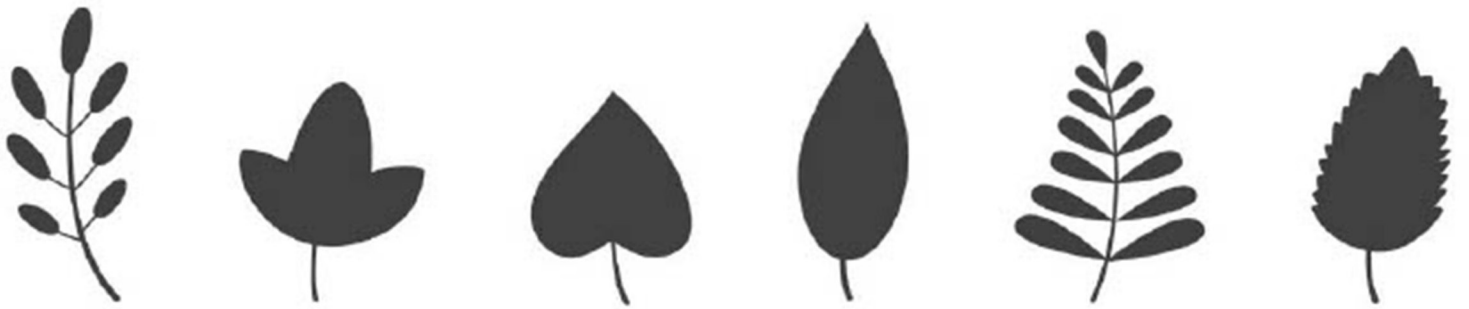



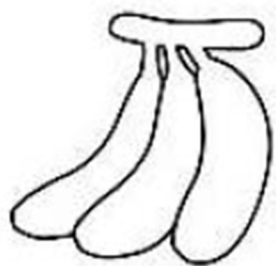
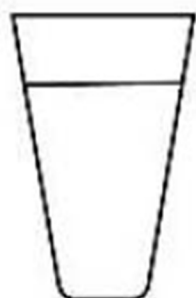
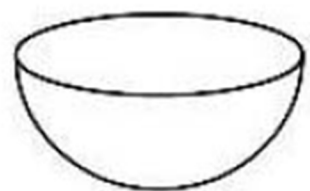
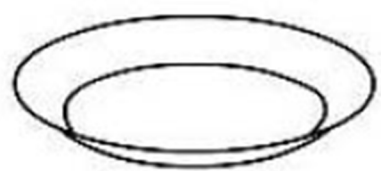





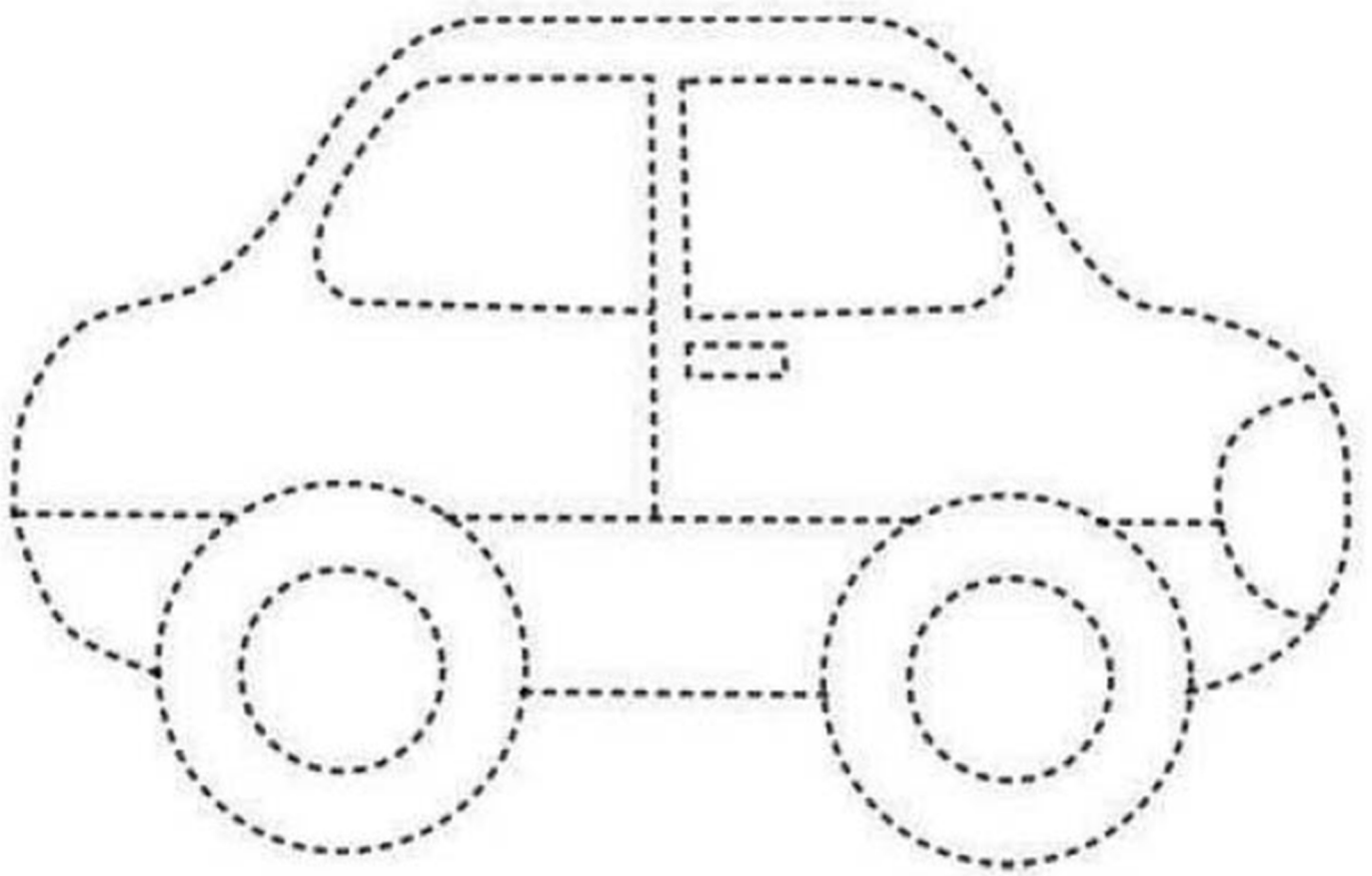

Follow the dots with your pen

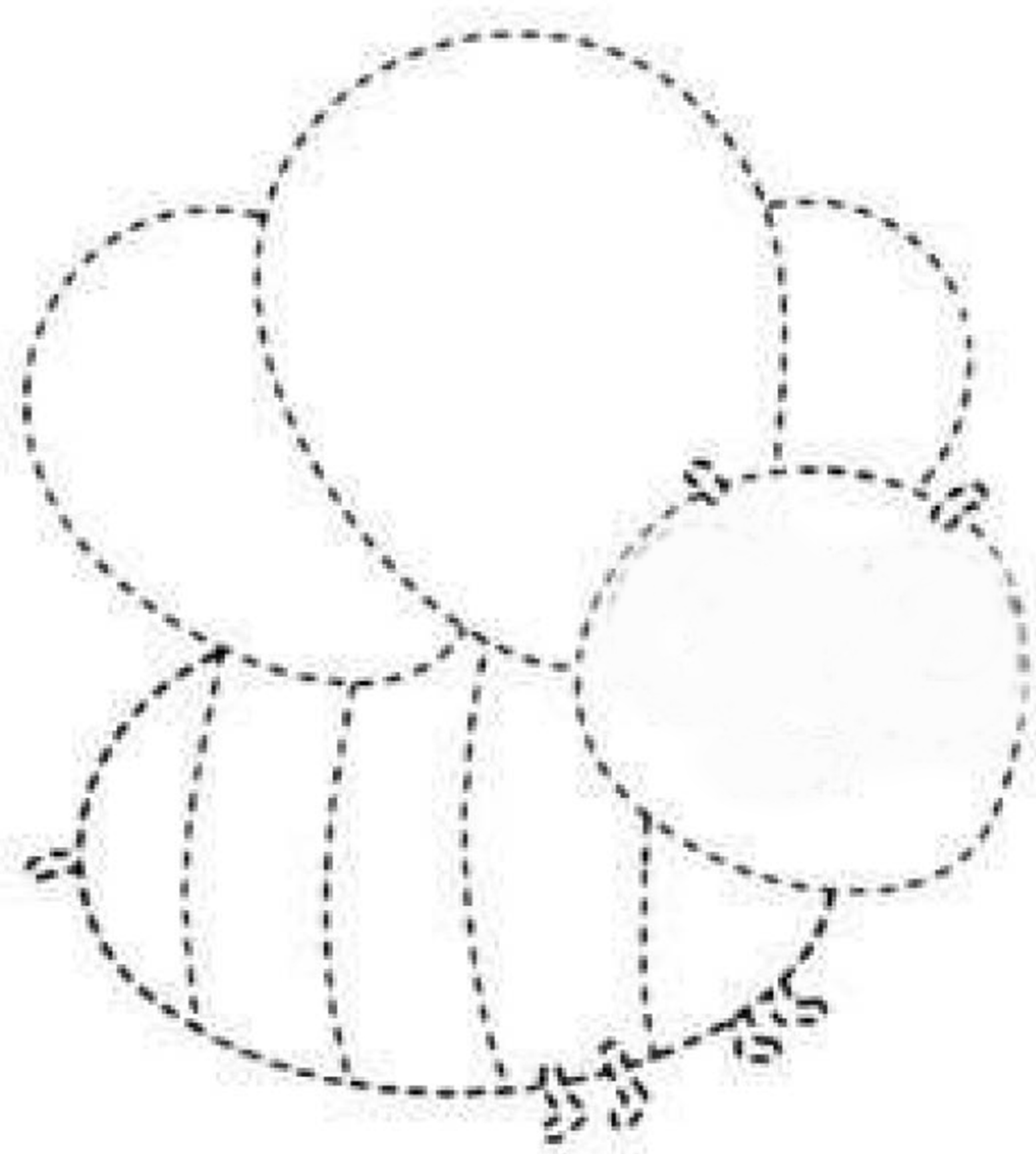

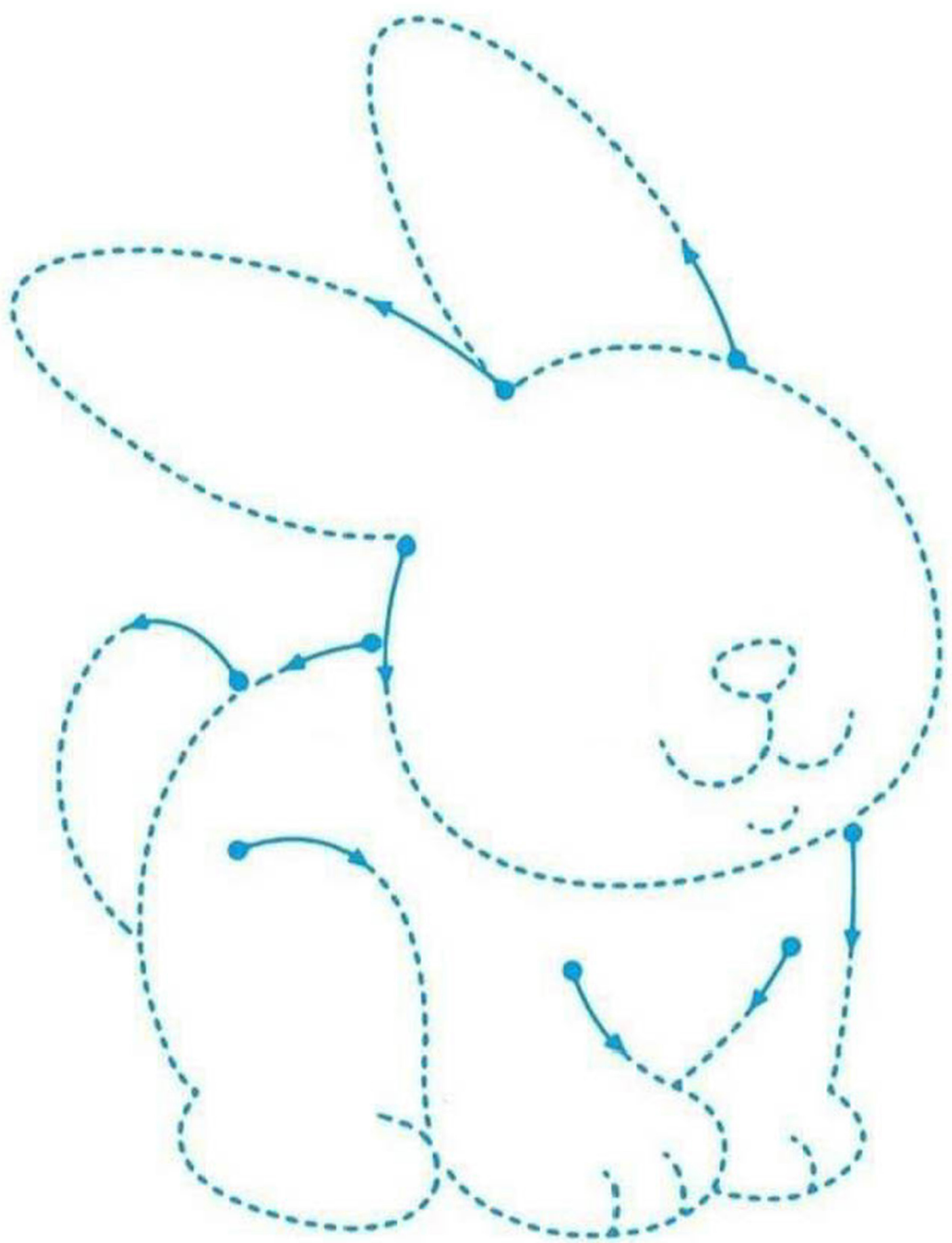

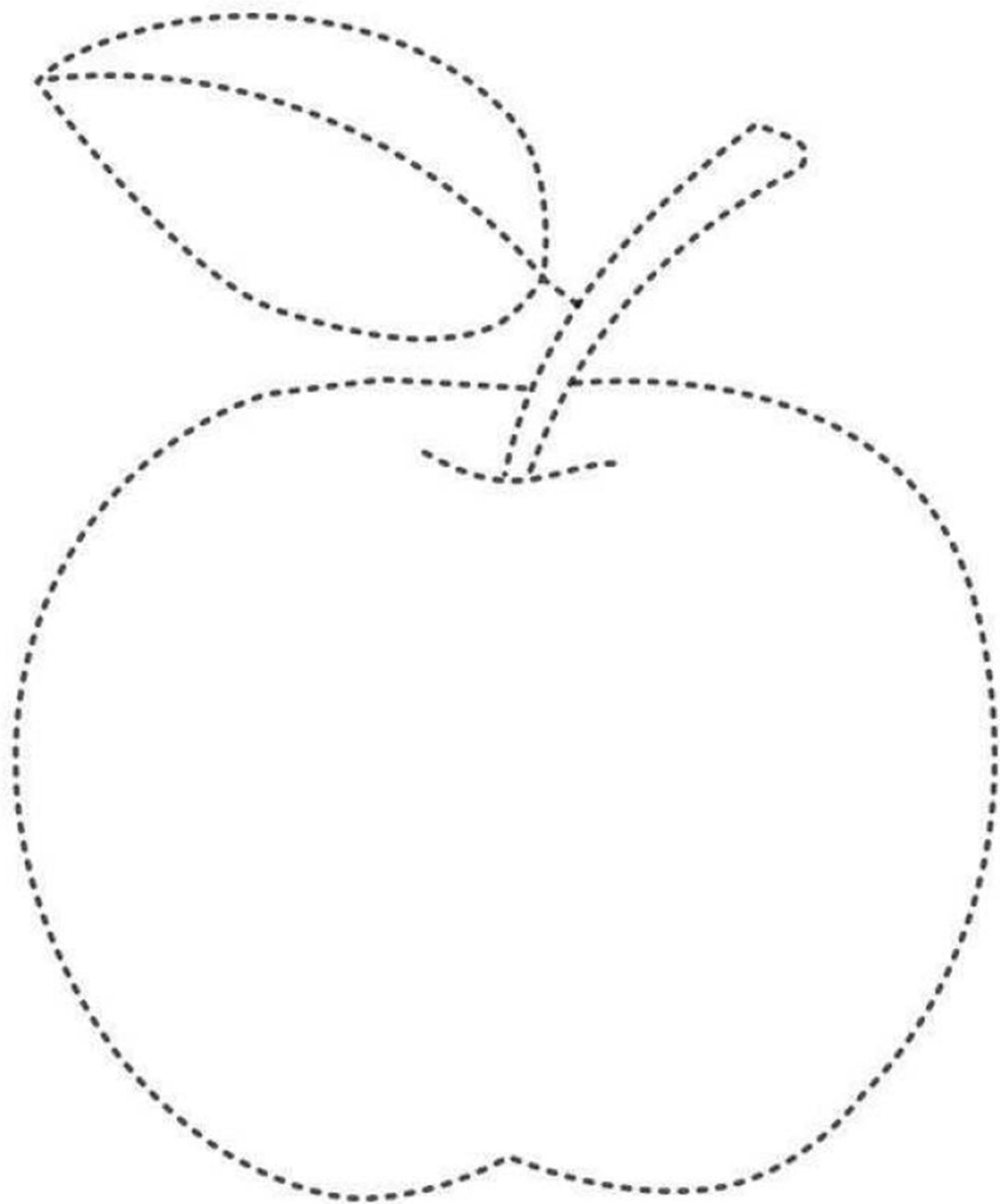

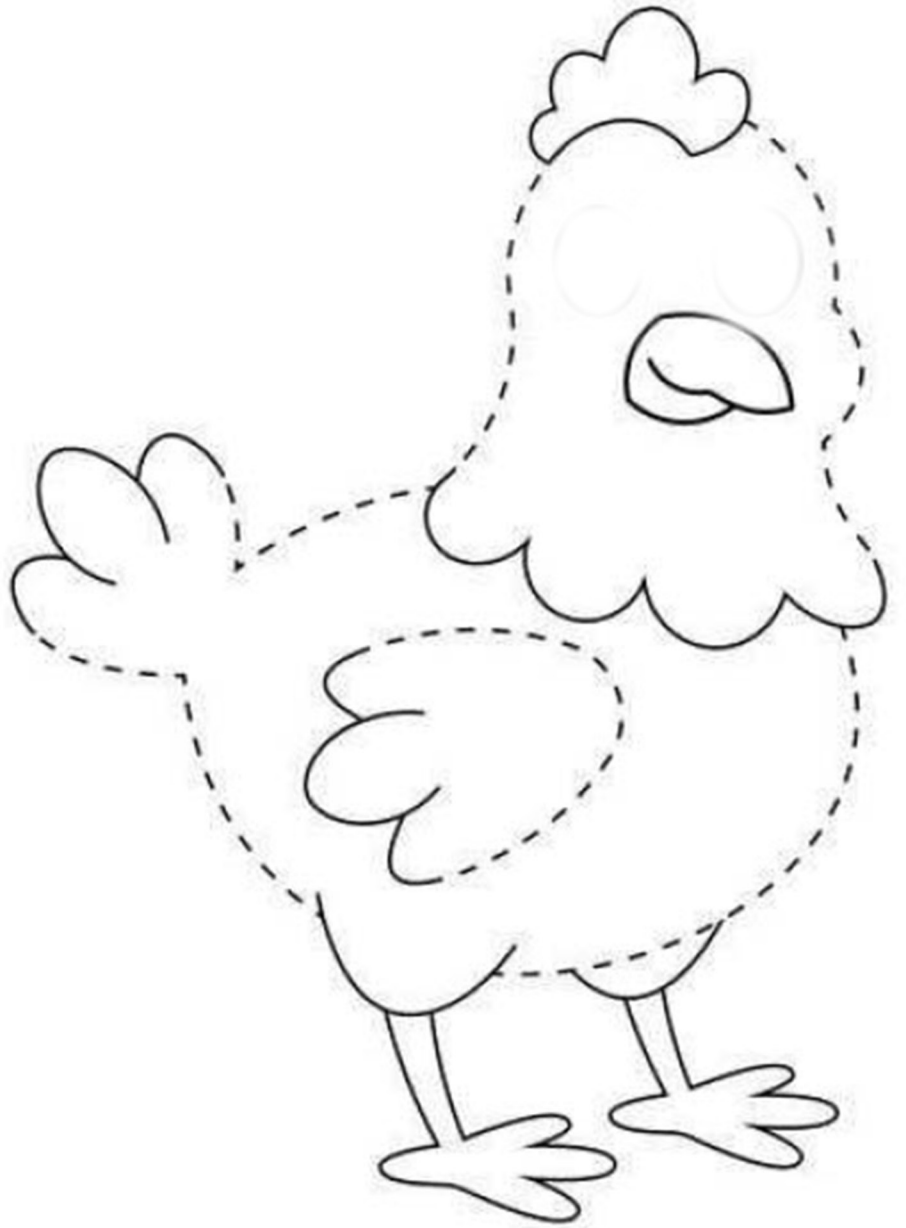

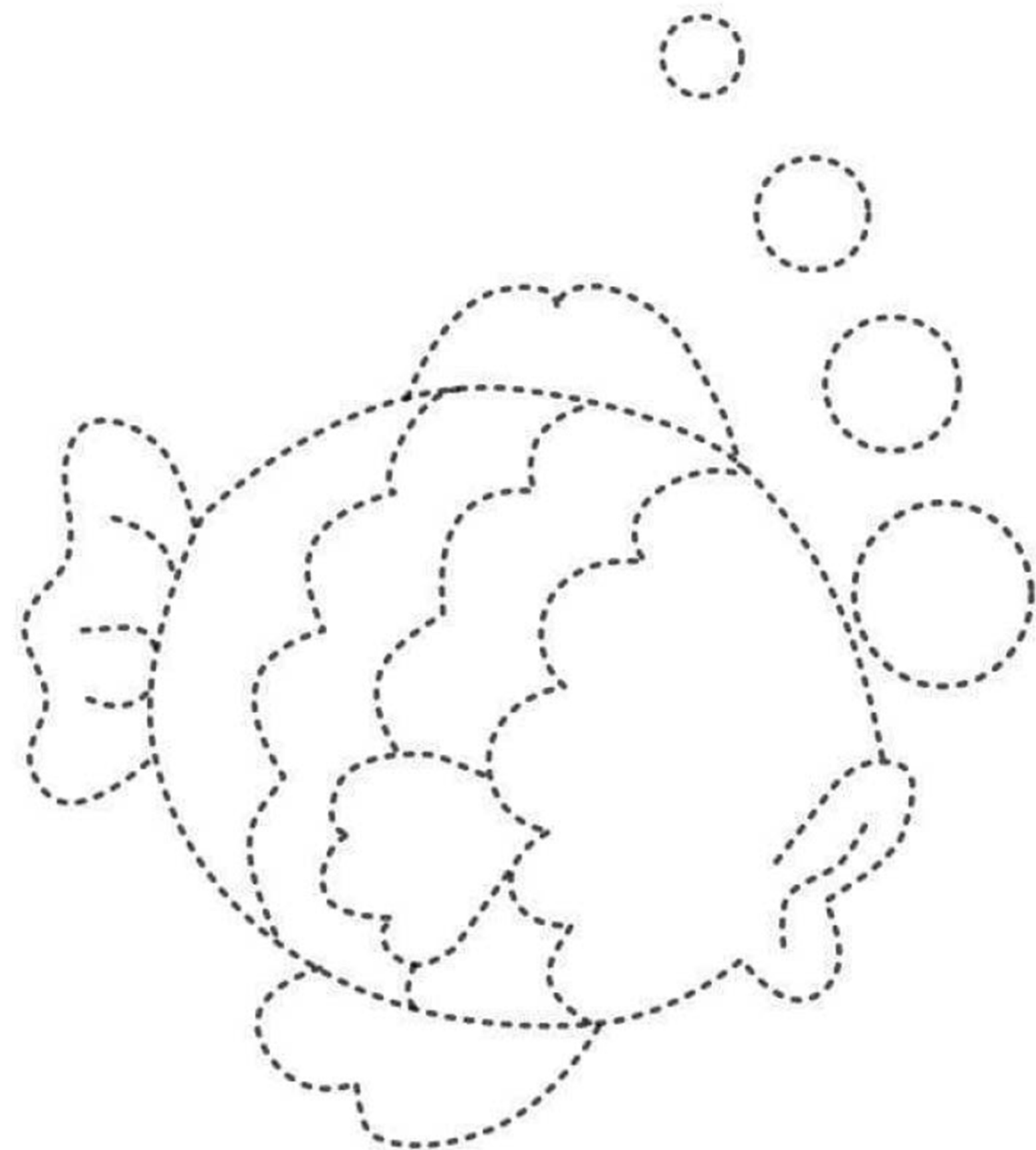

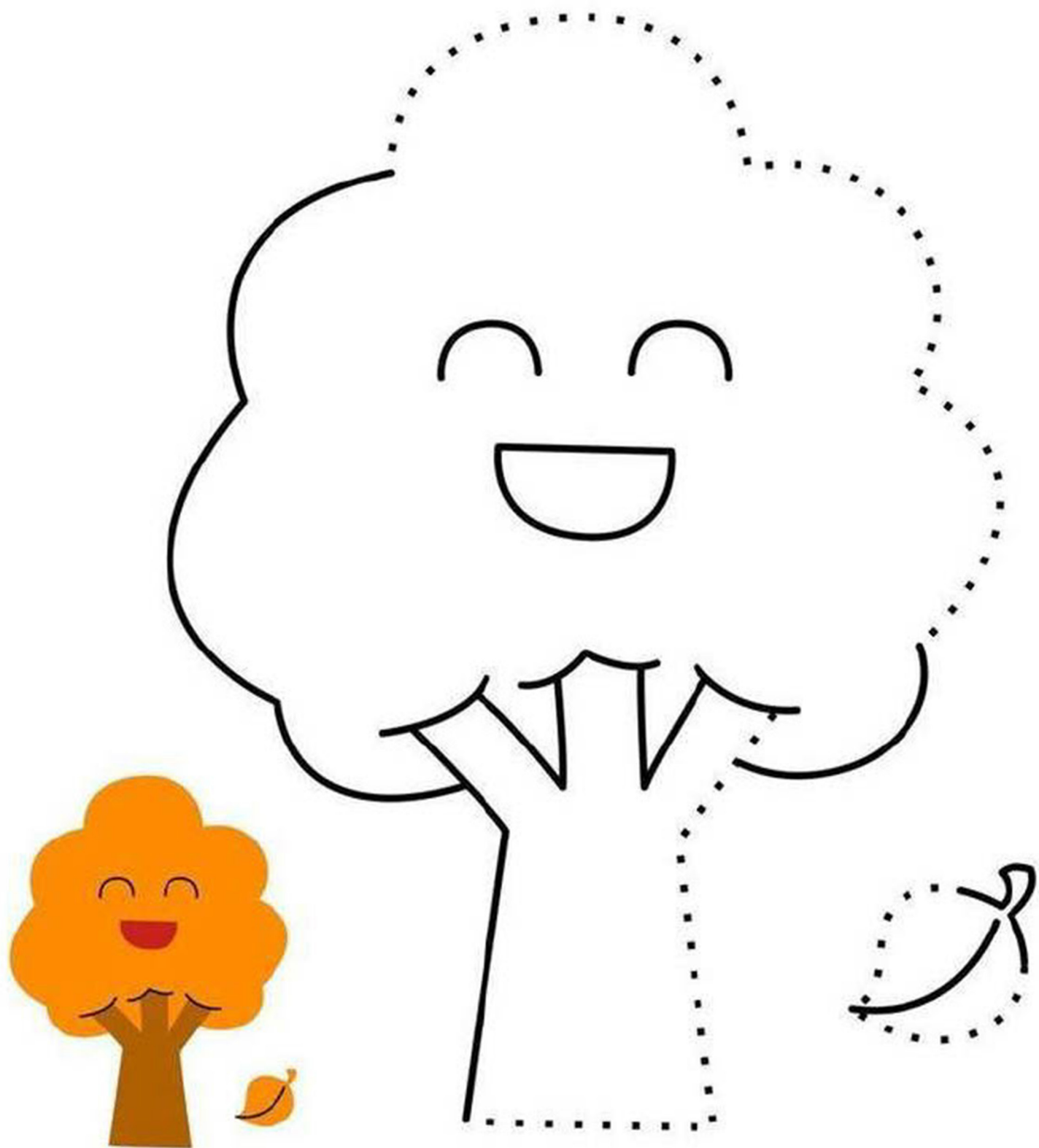

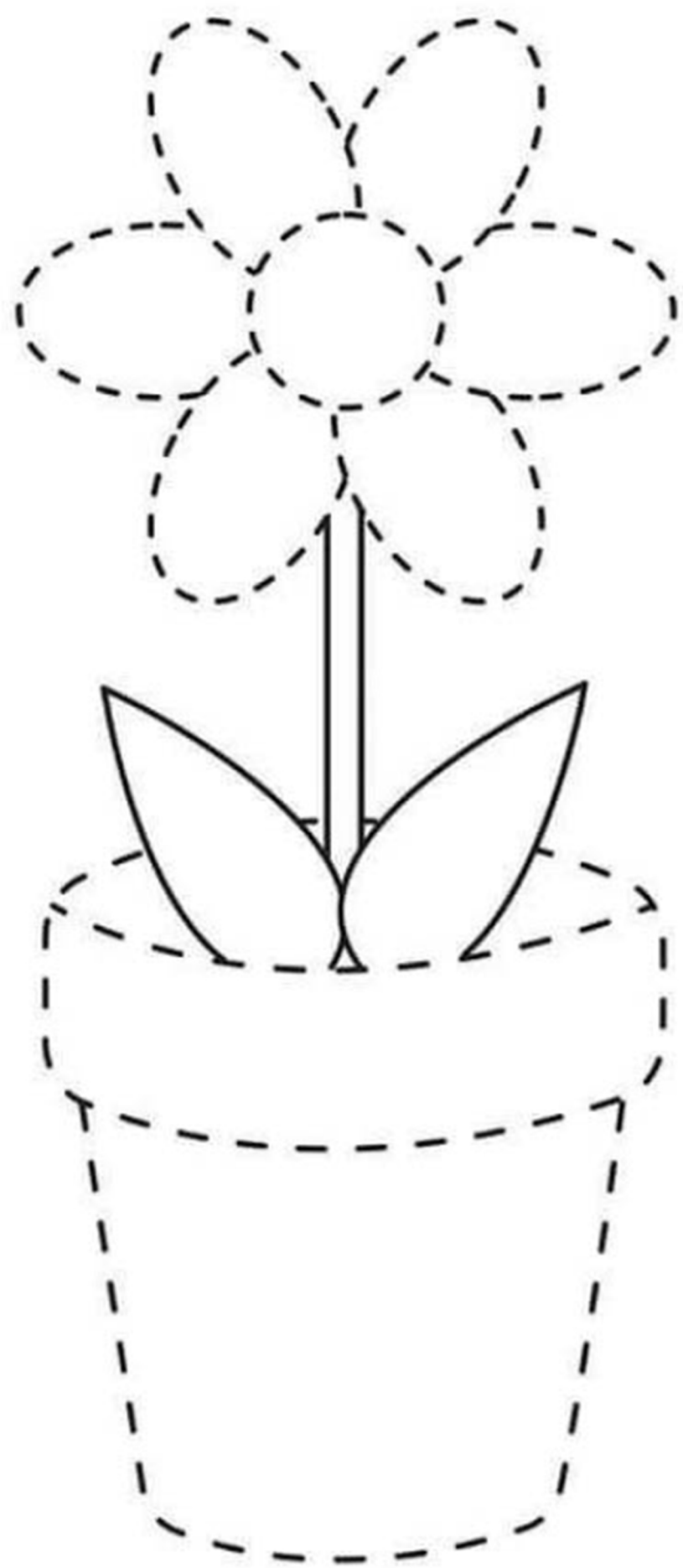

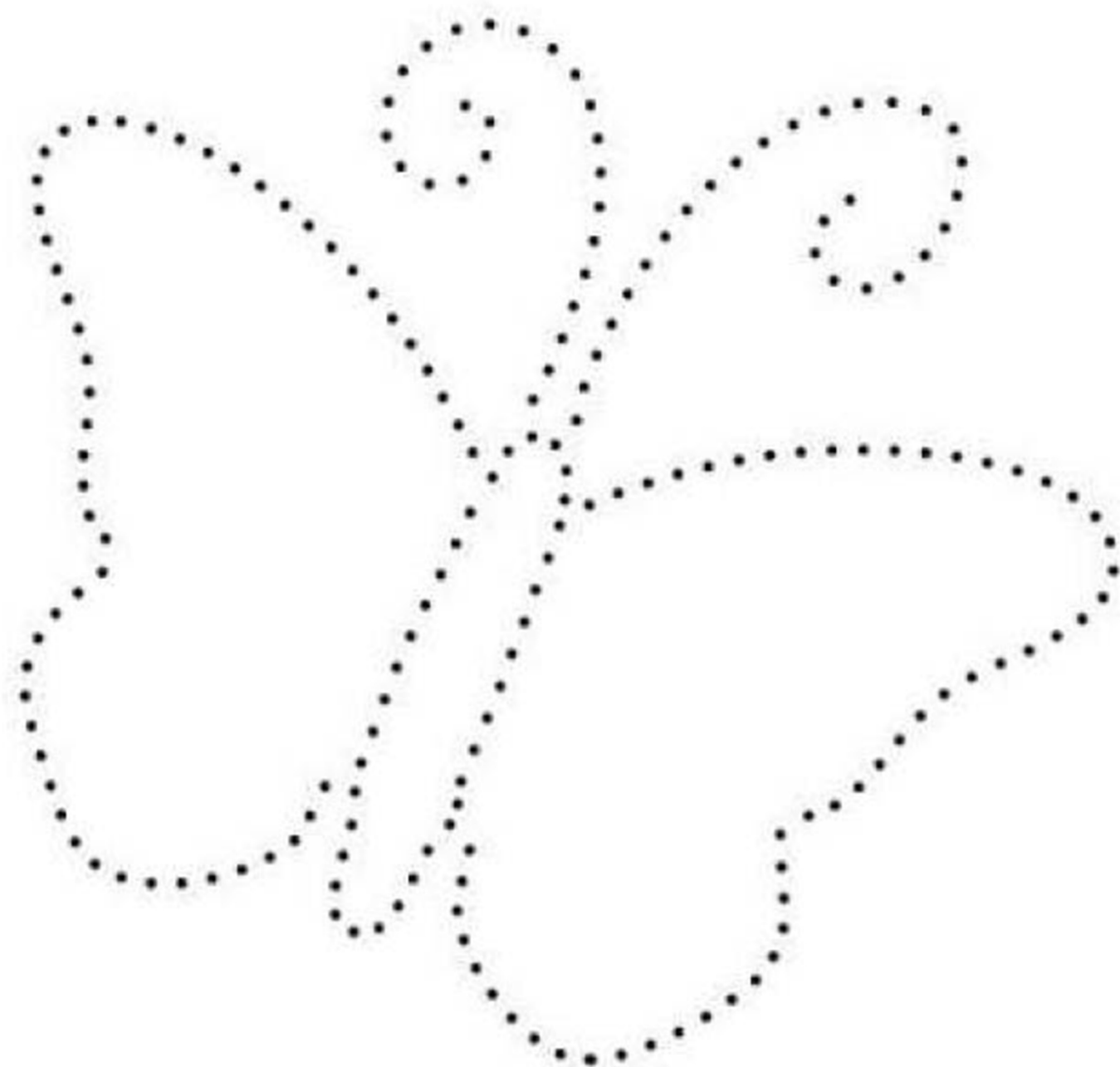

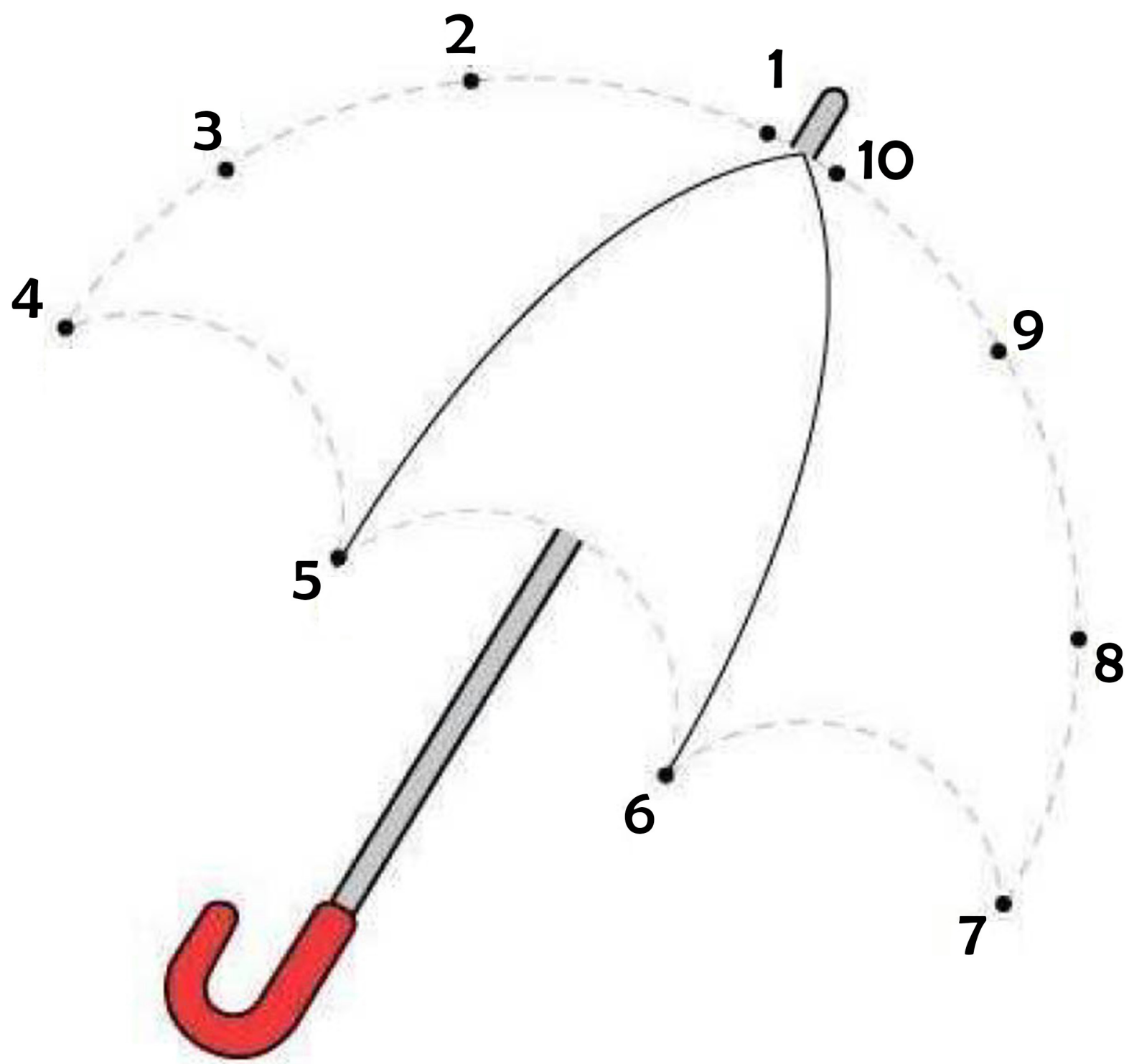

Connect the numbers
with your pen

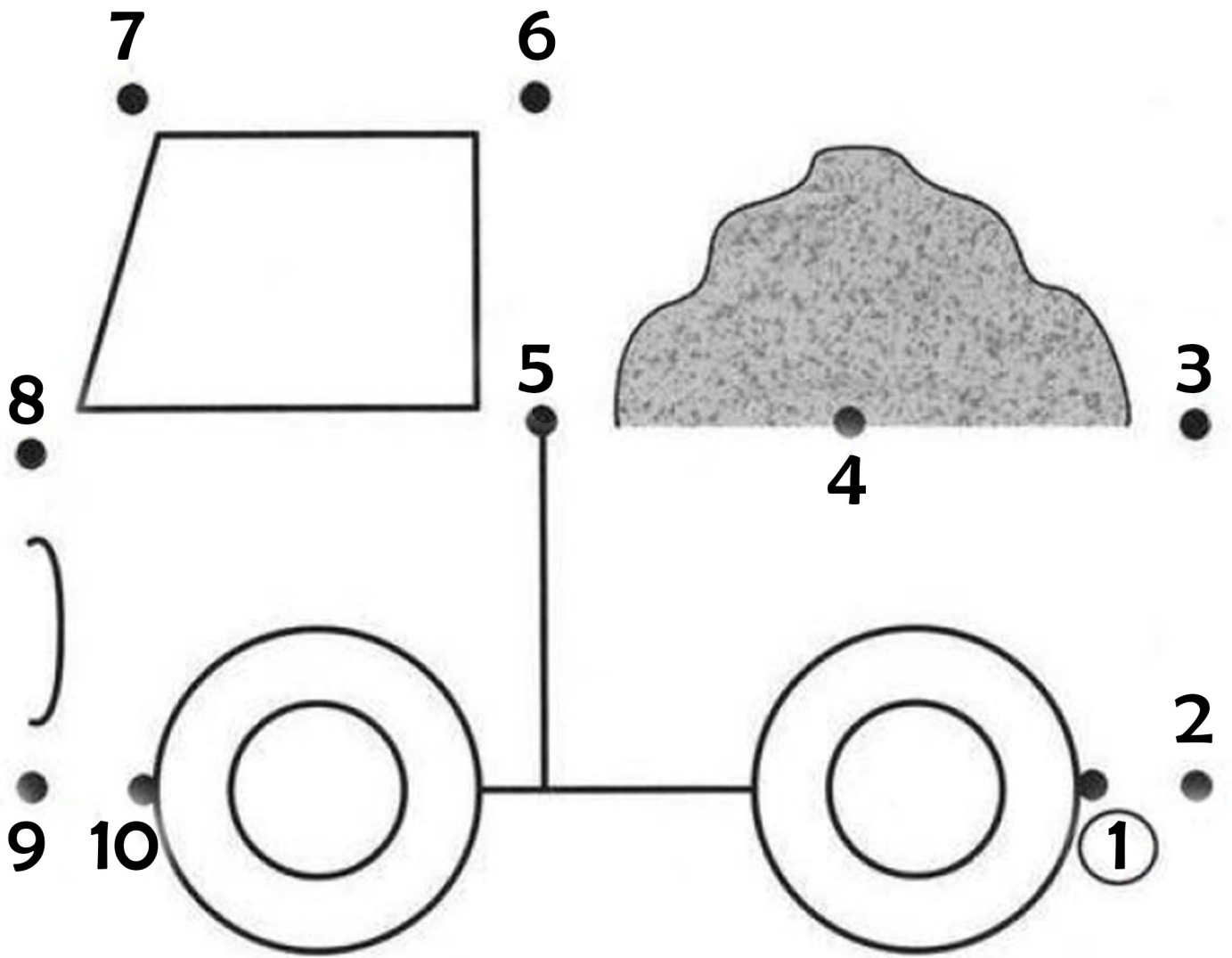

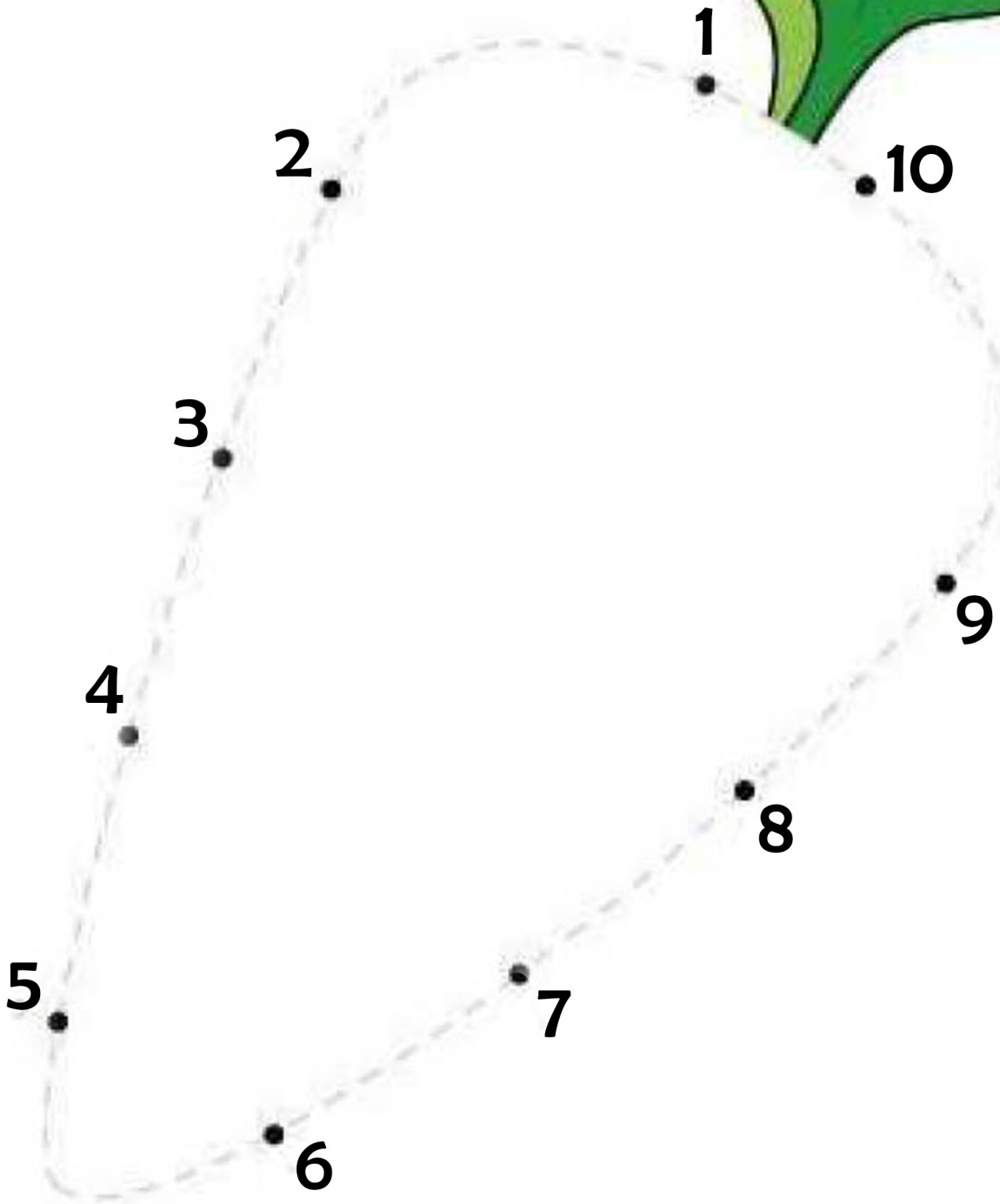

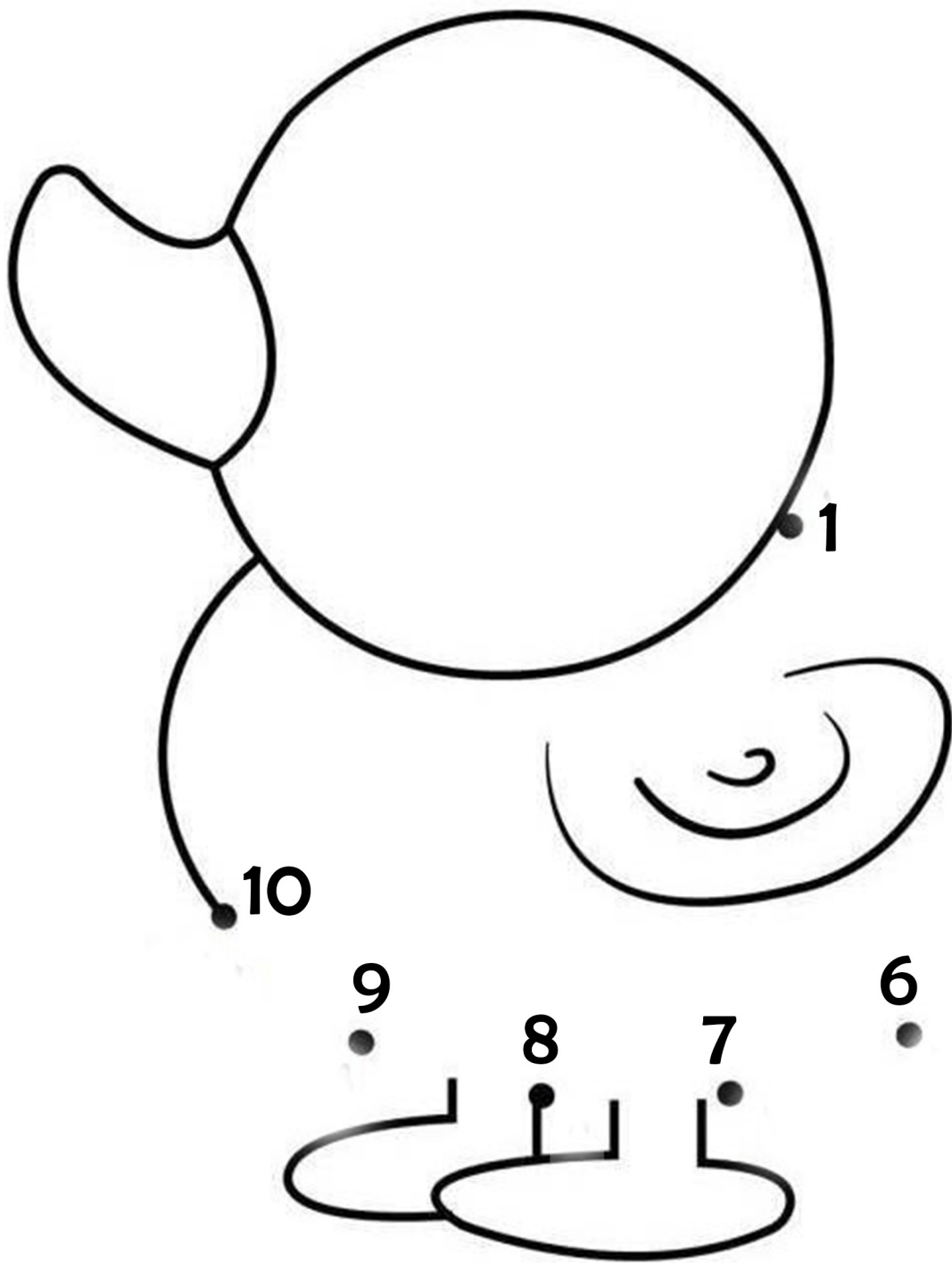

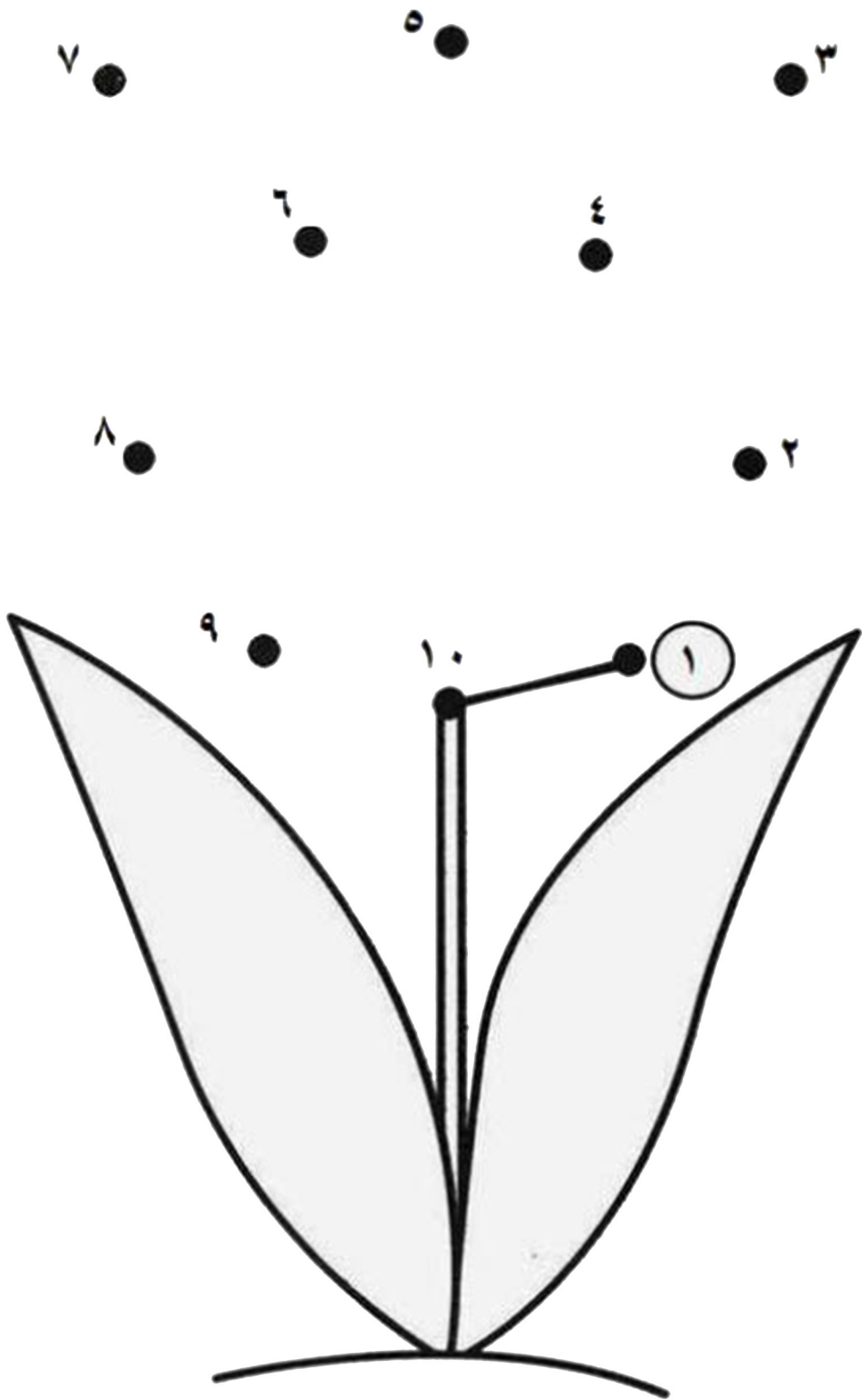

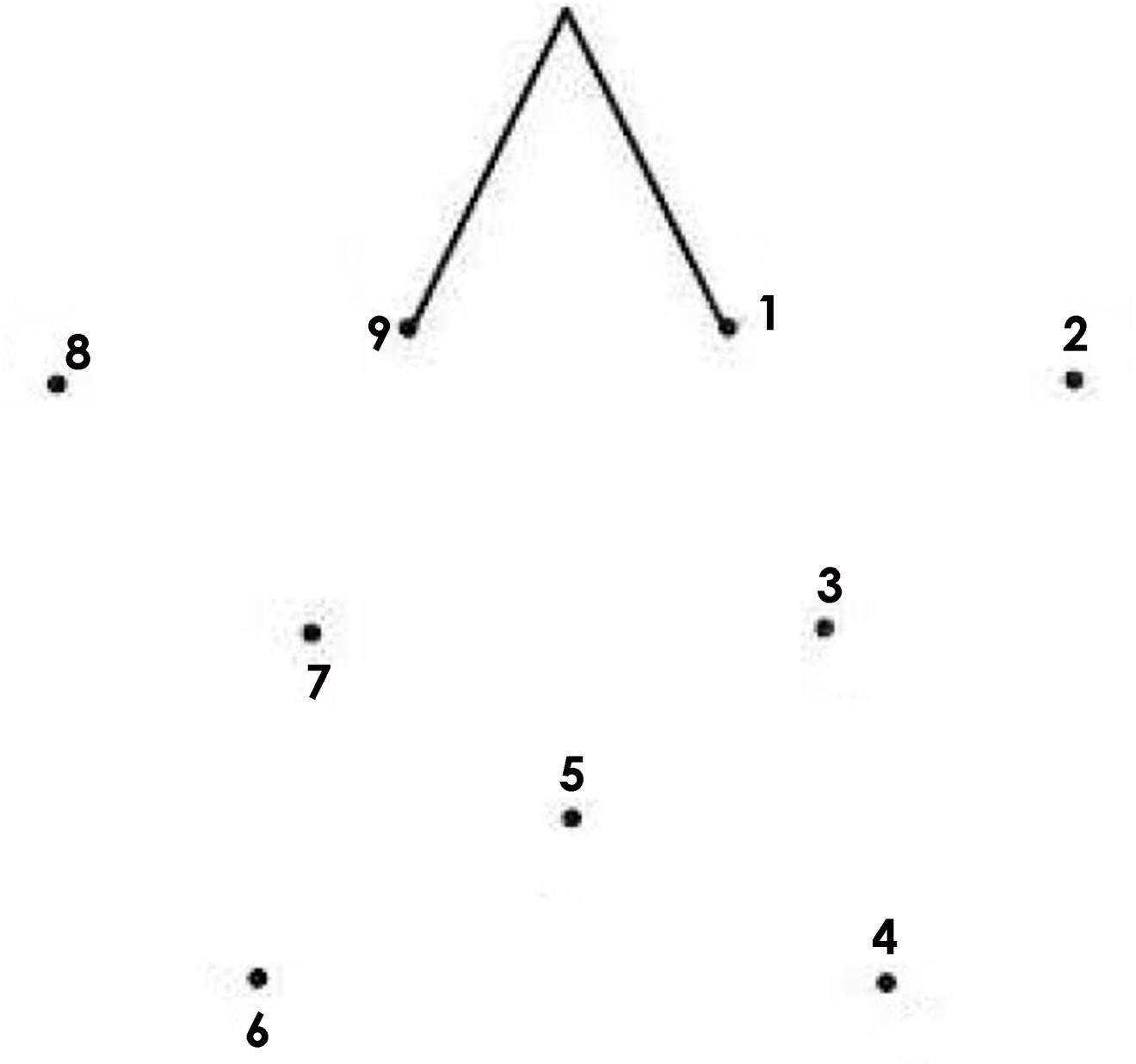

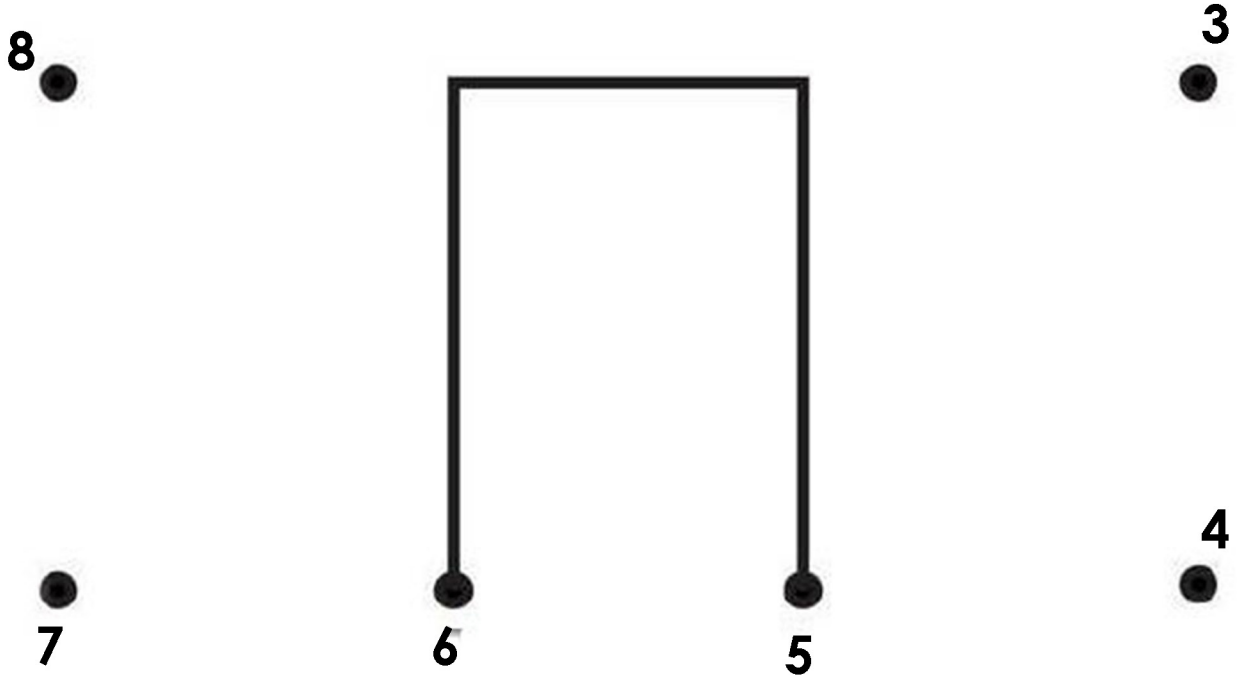
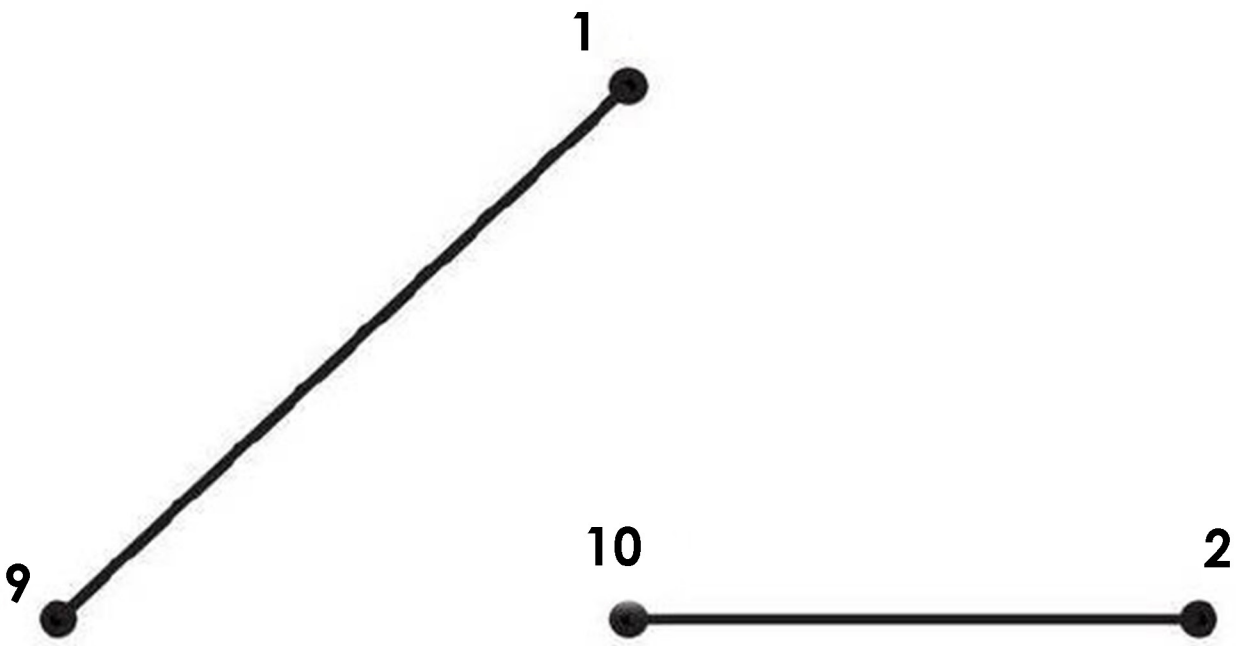

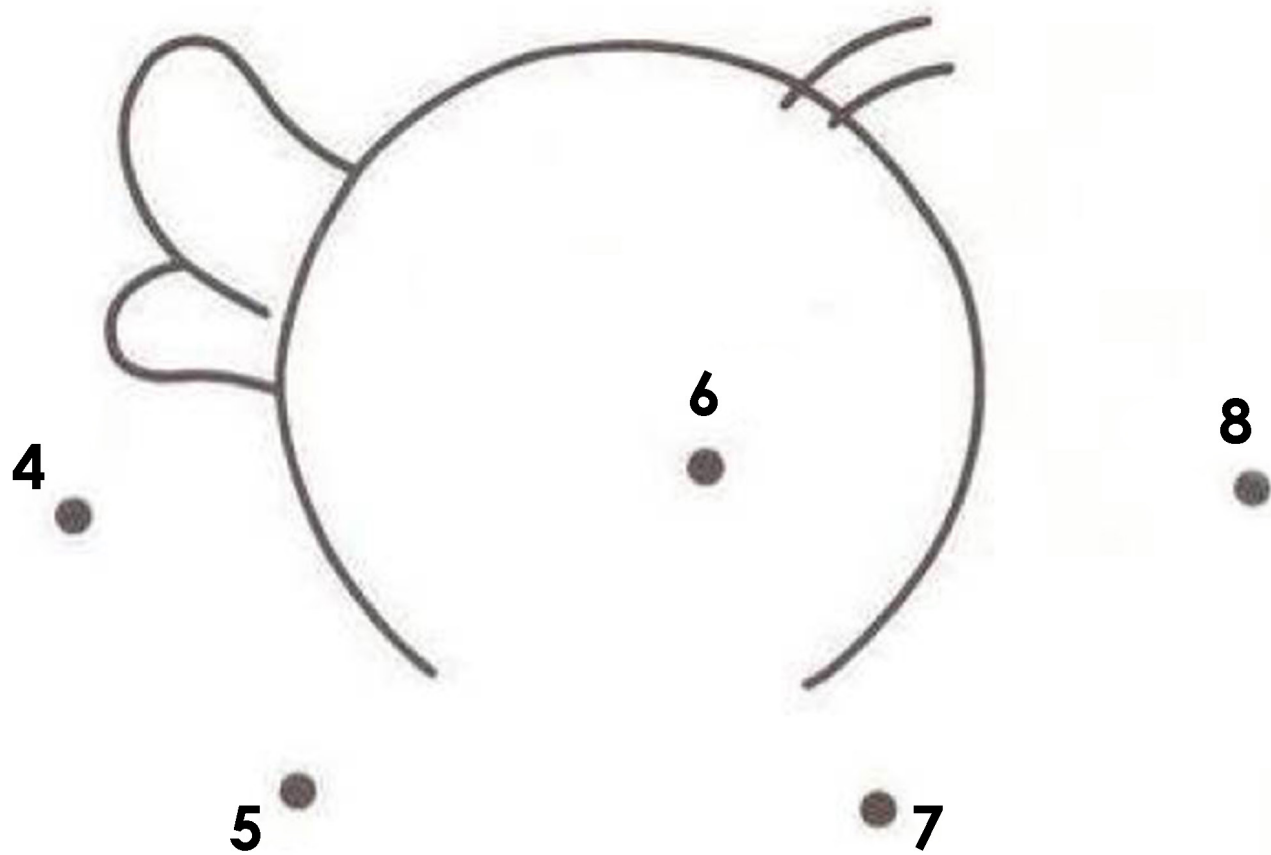



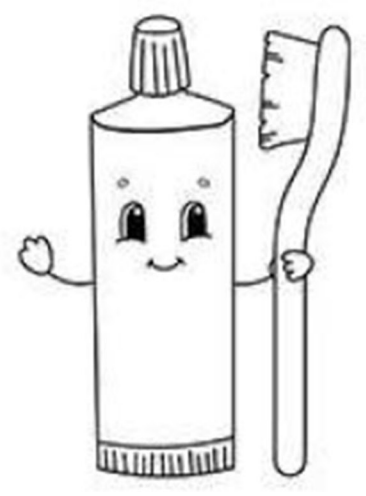
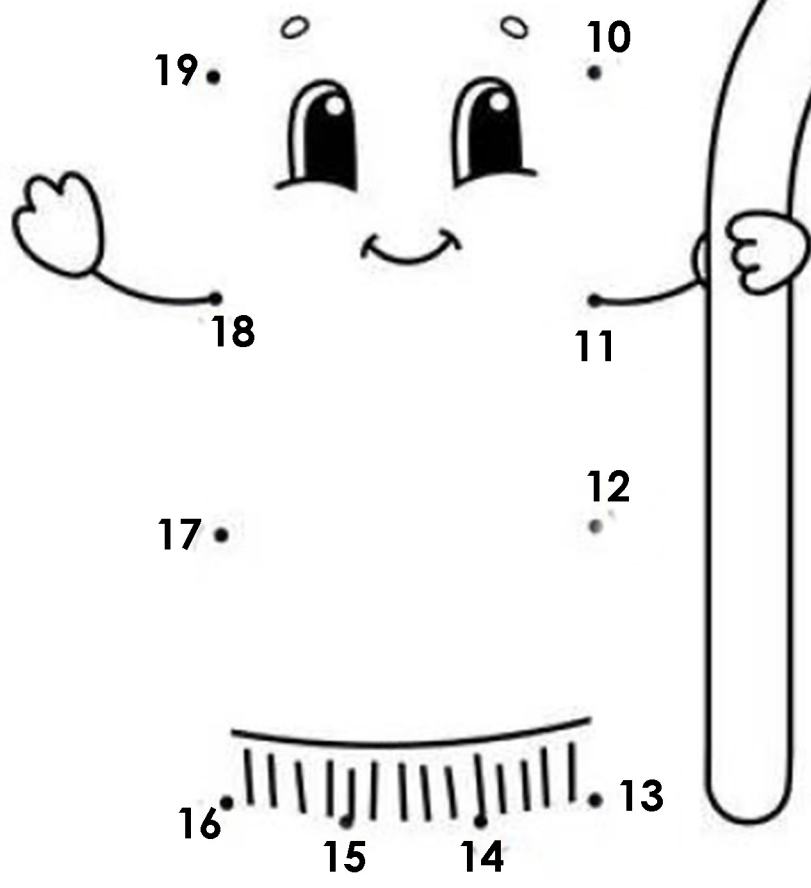
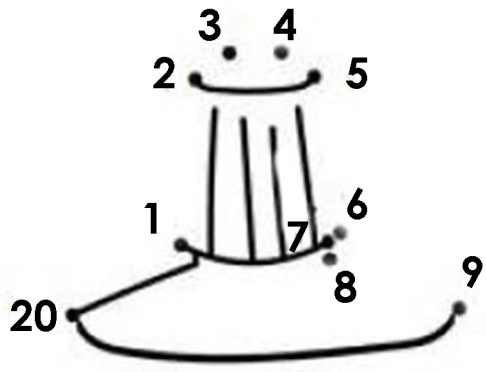

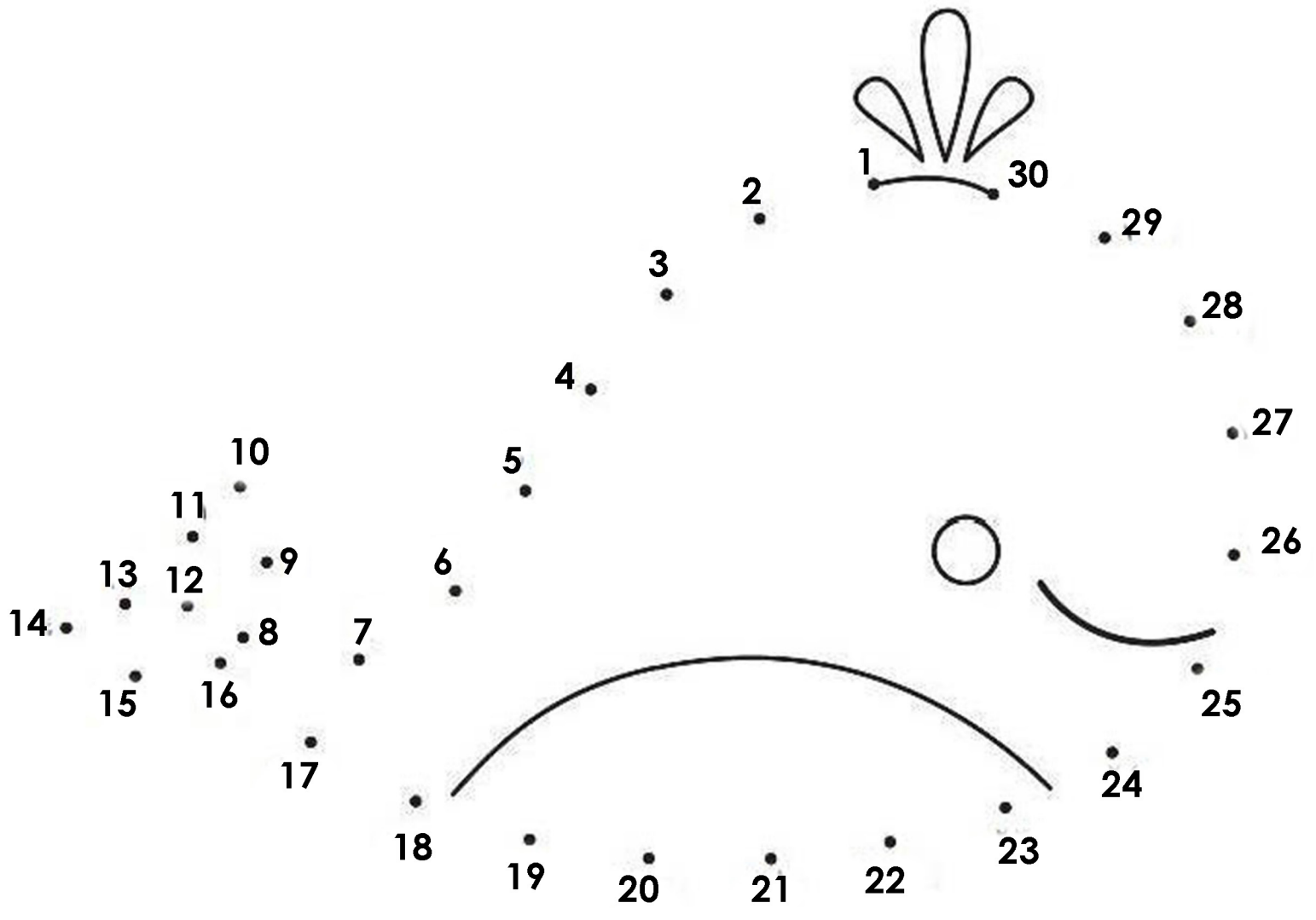

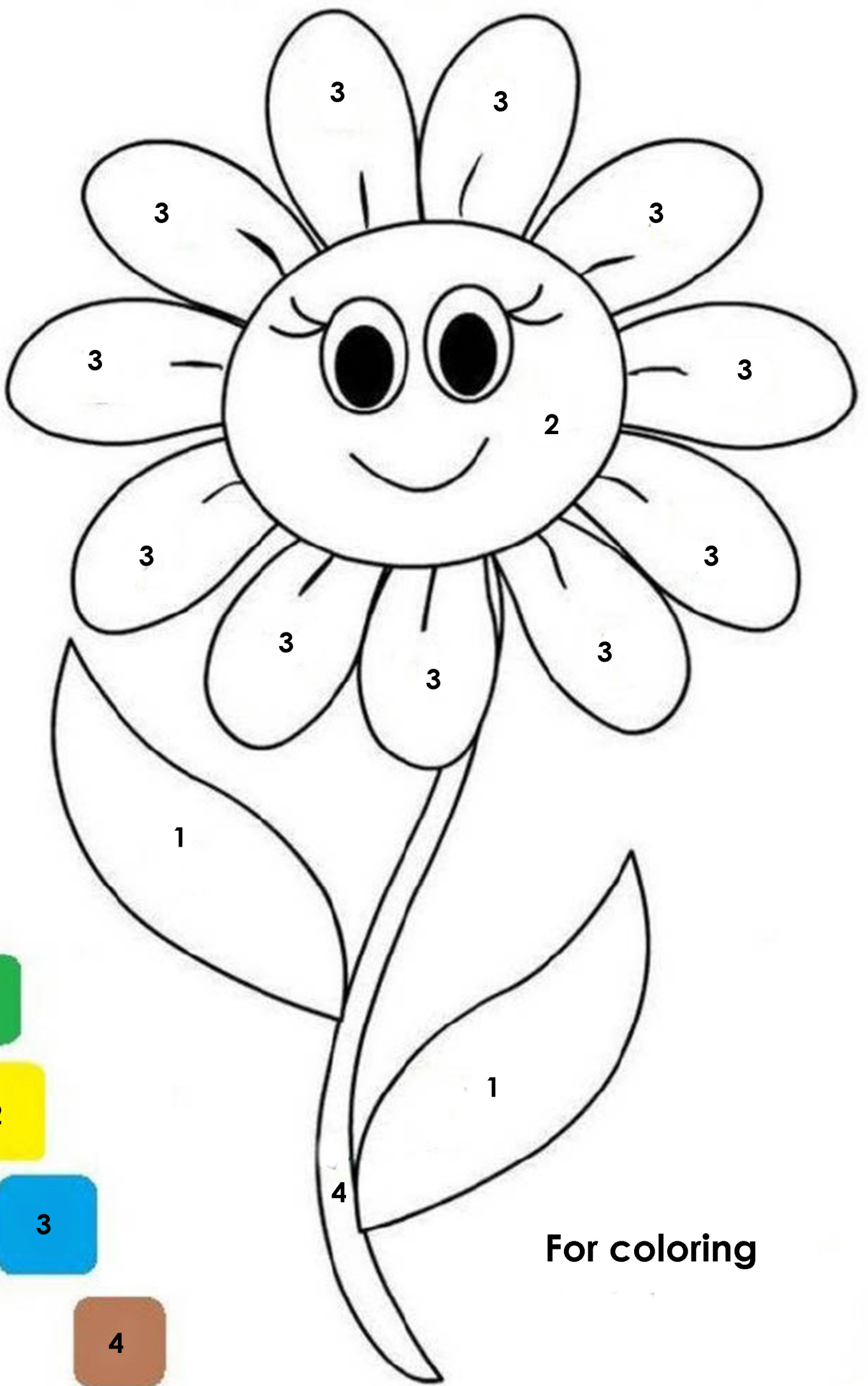

For coloring



1



2



3



4





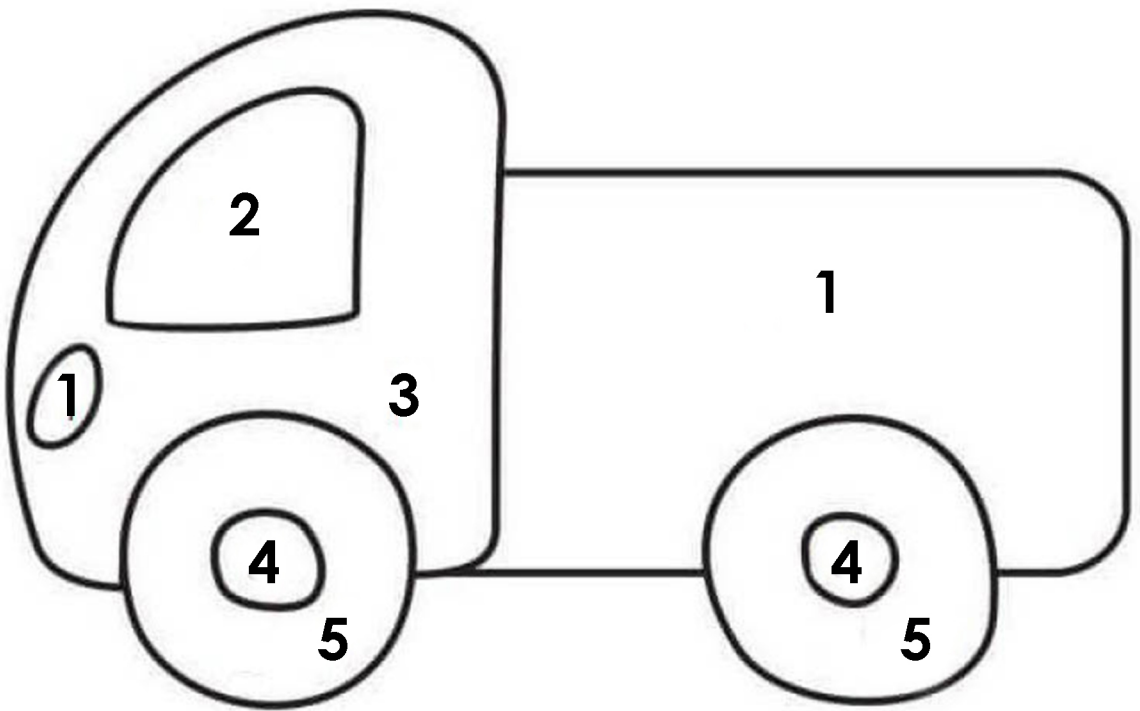

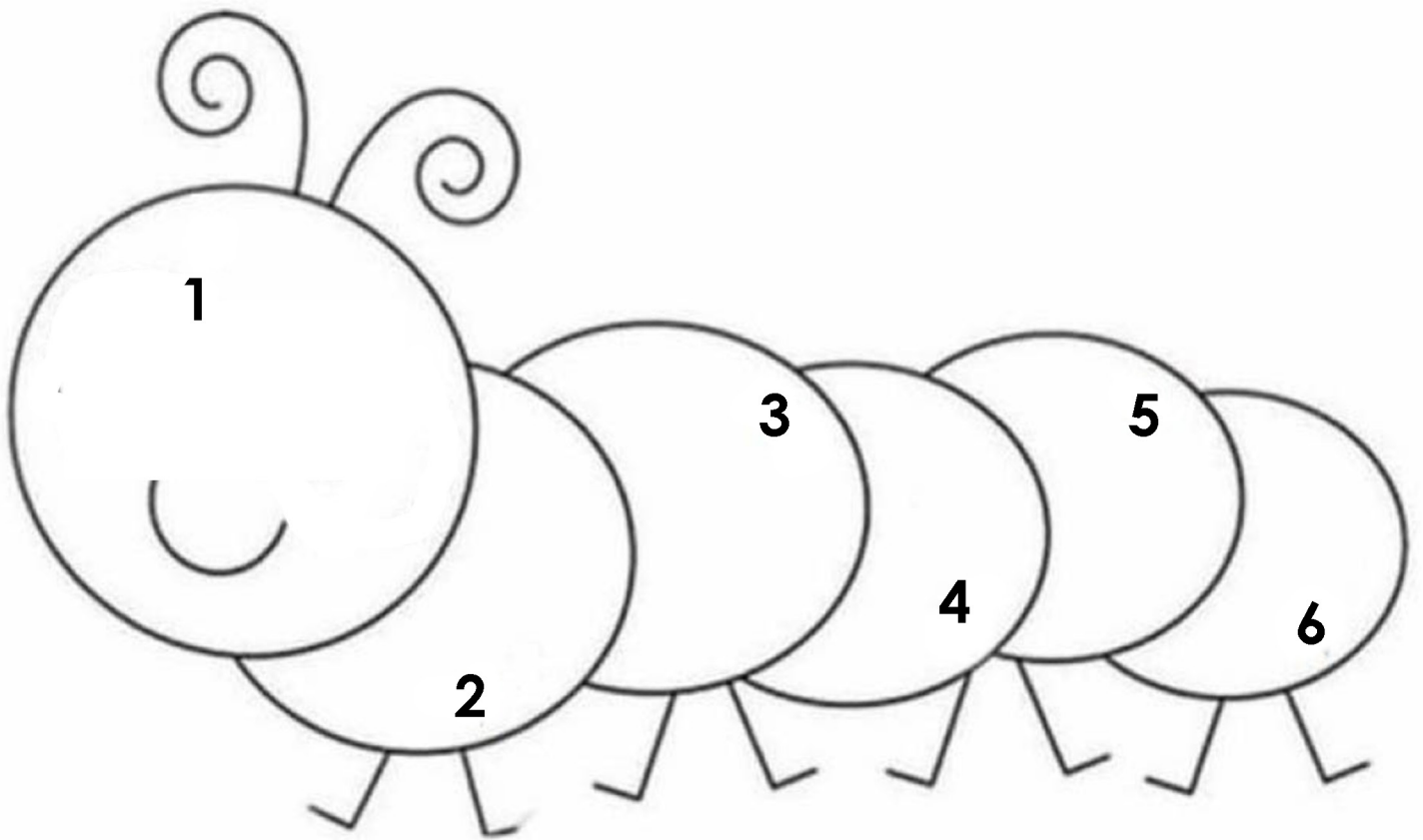
5

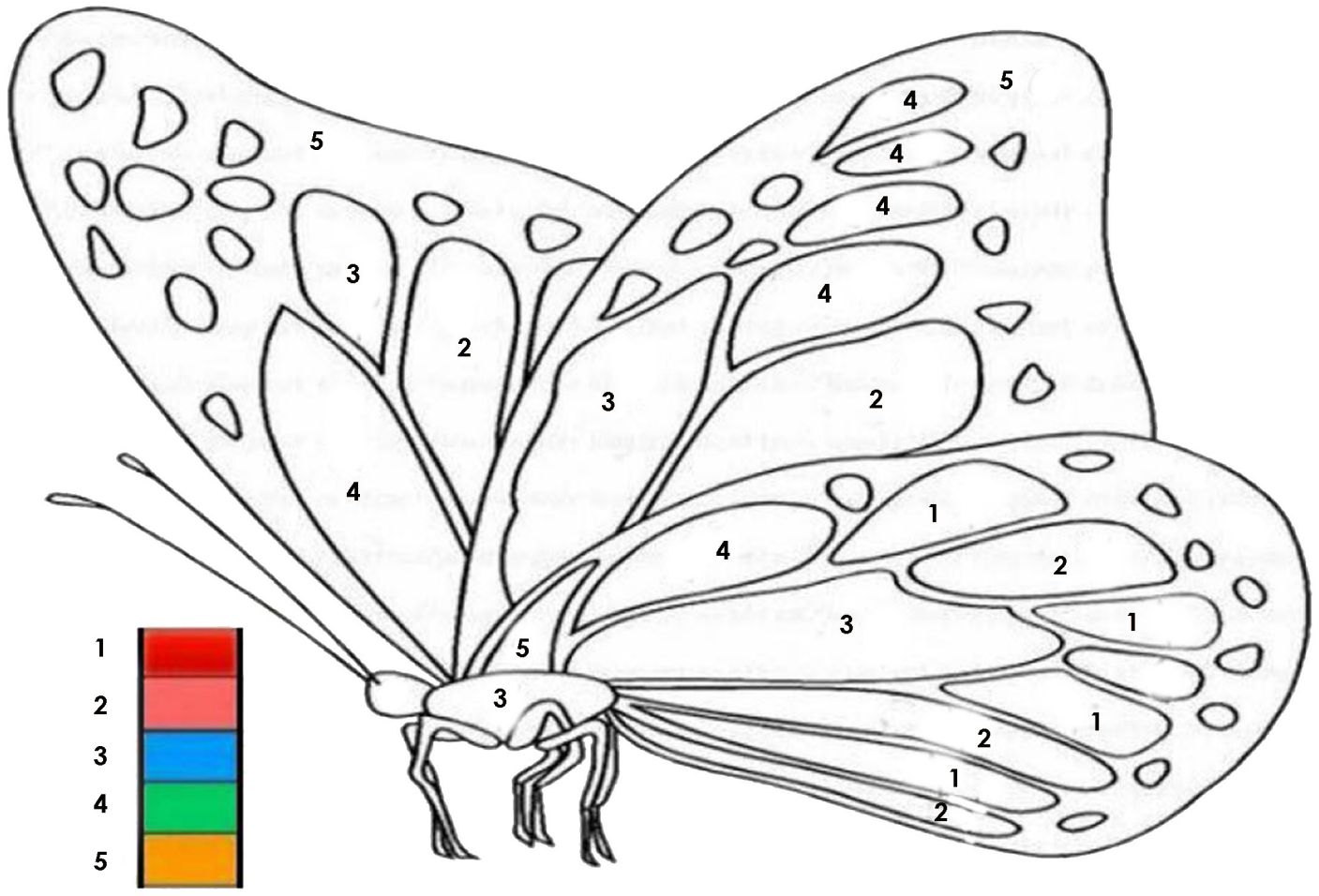



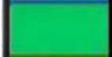

- 1 
- 2 
- 3 
- 4 
- 5 



1



2



3



4

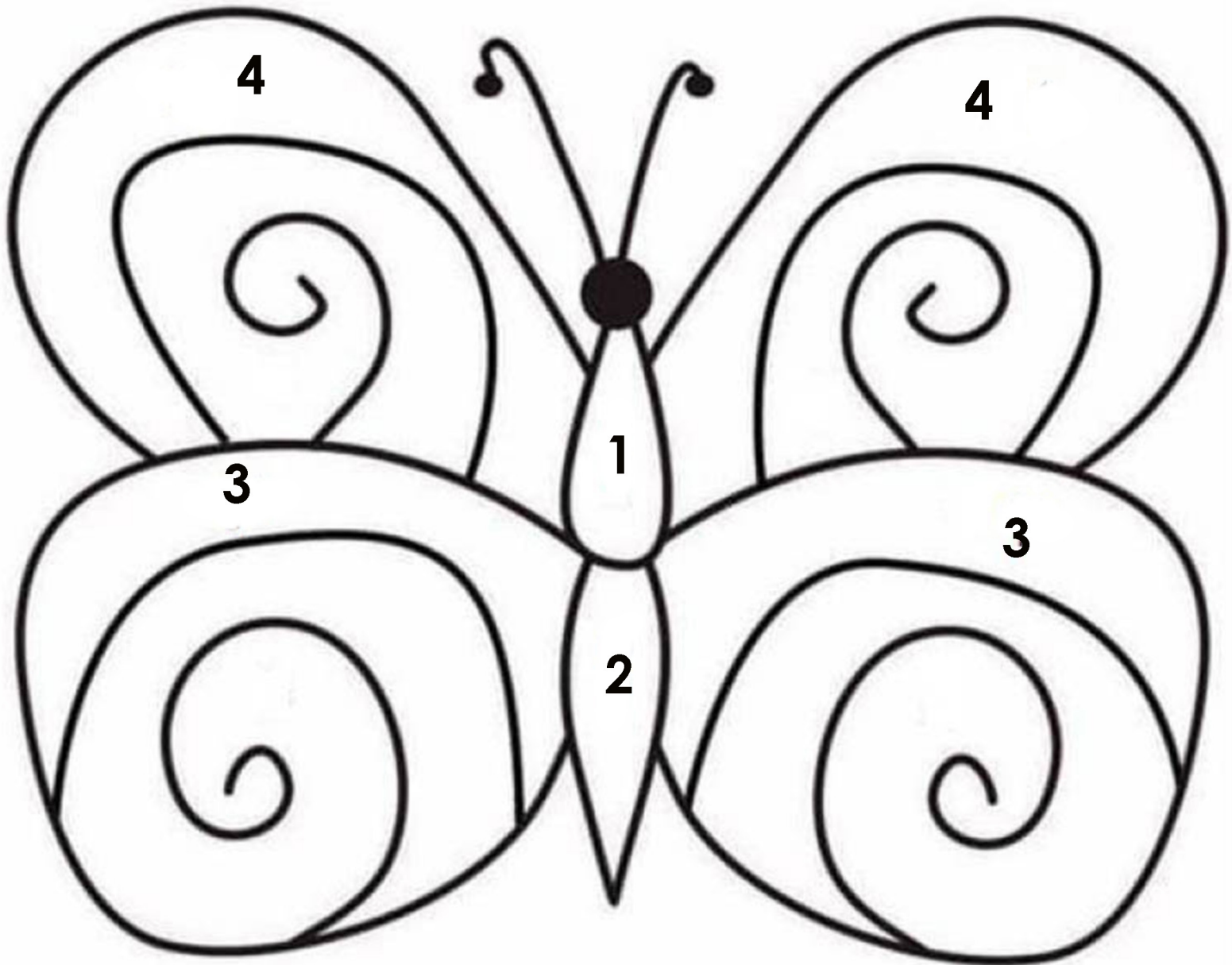

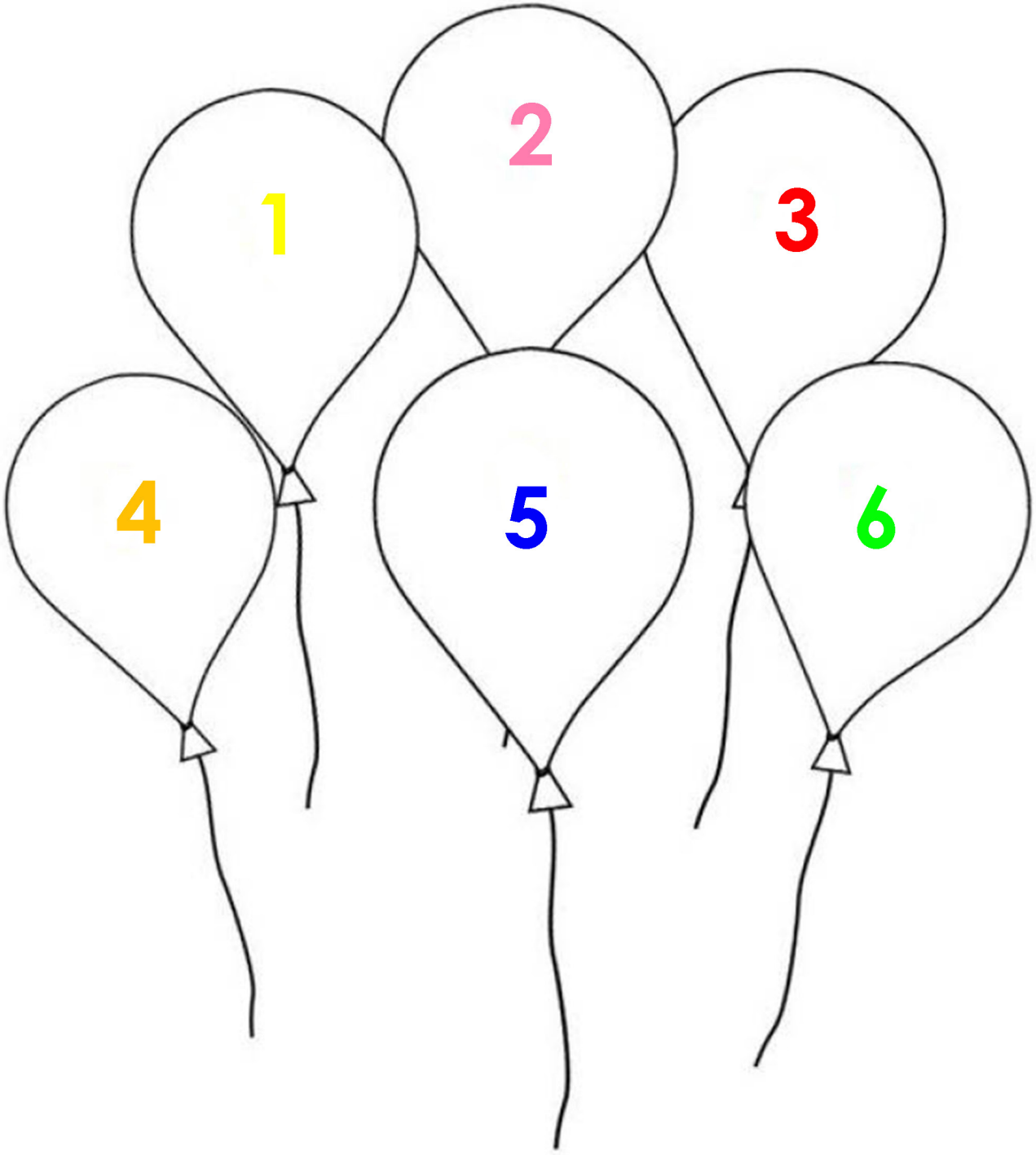

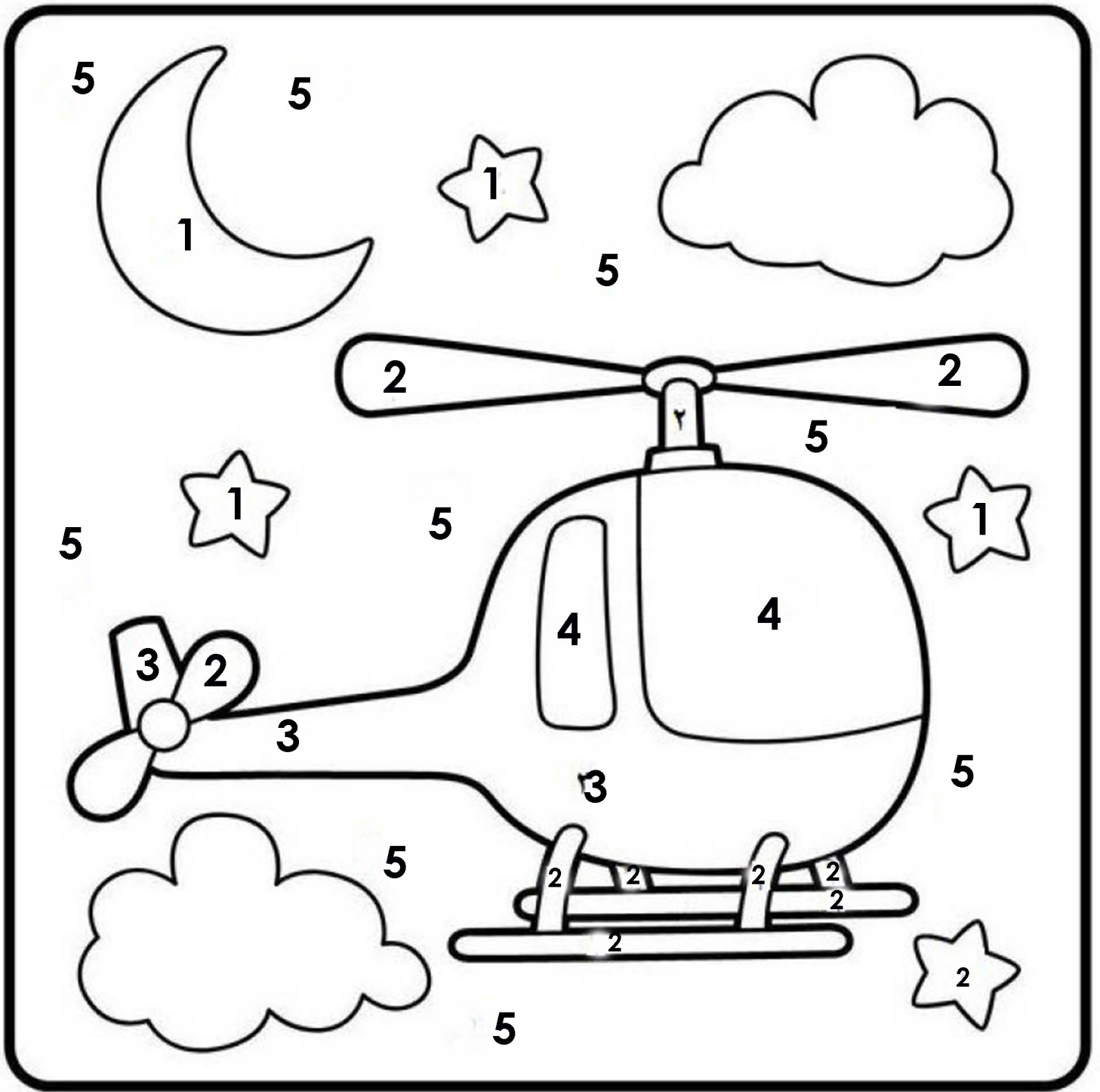

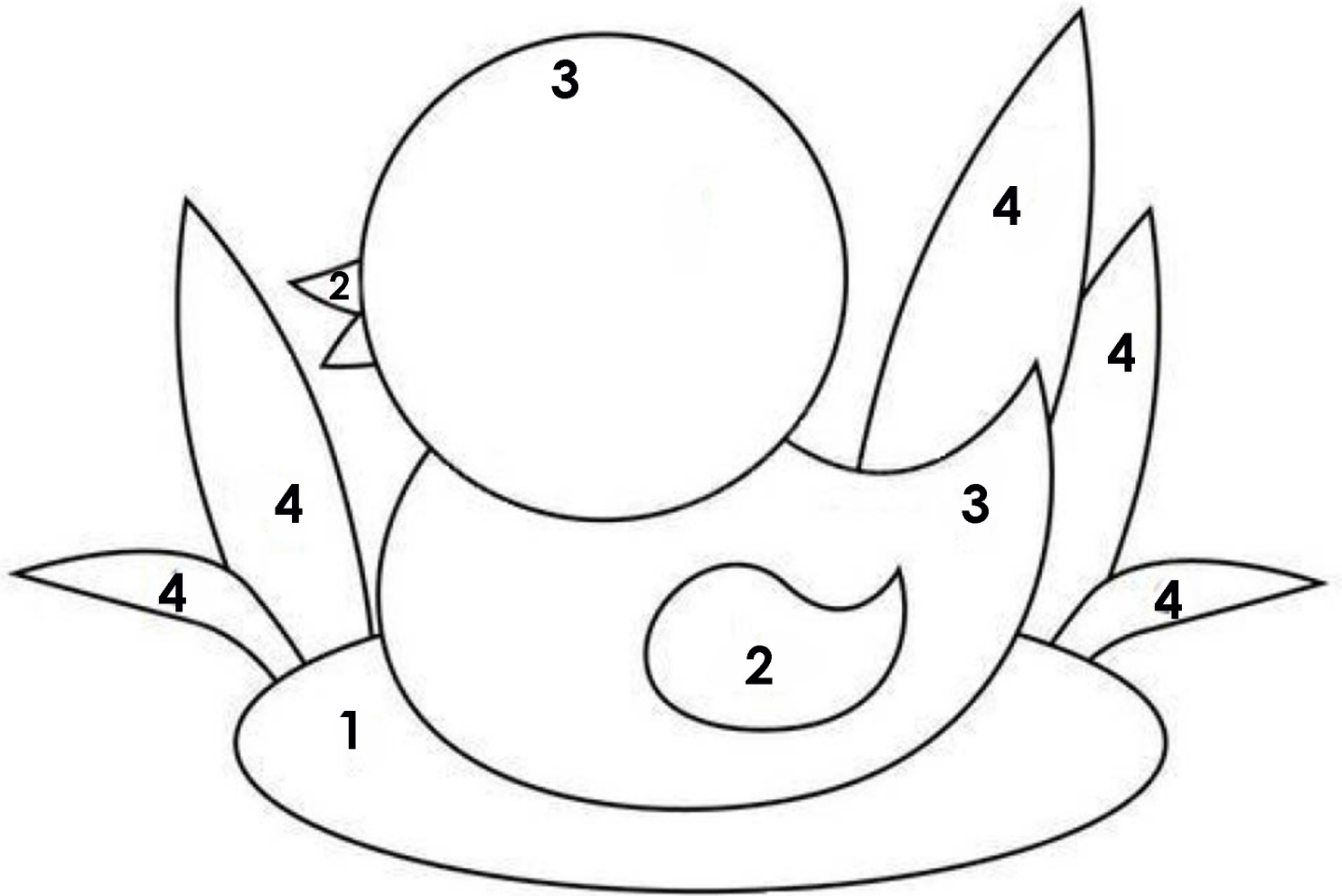

1 ●

3 ●

2 ●

4 ●



1



2



3



4



5



6



7



8

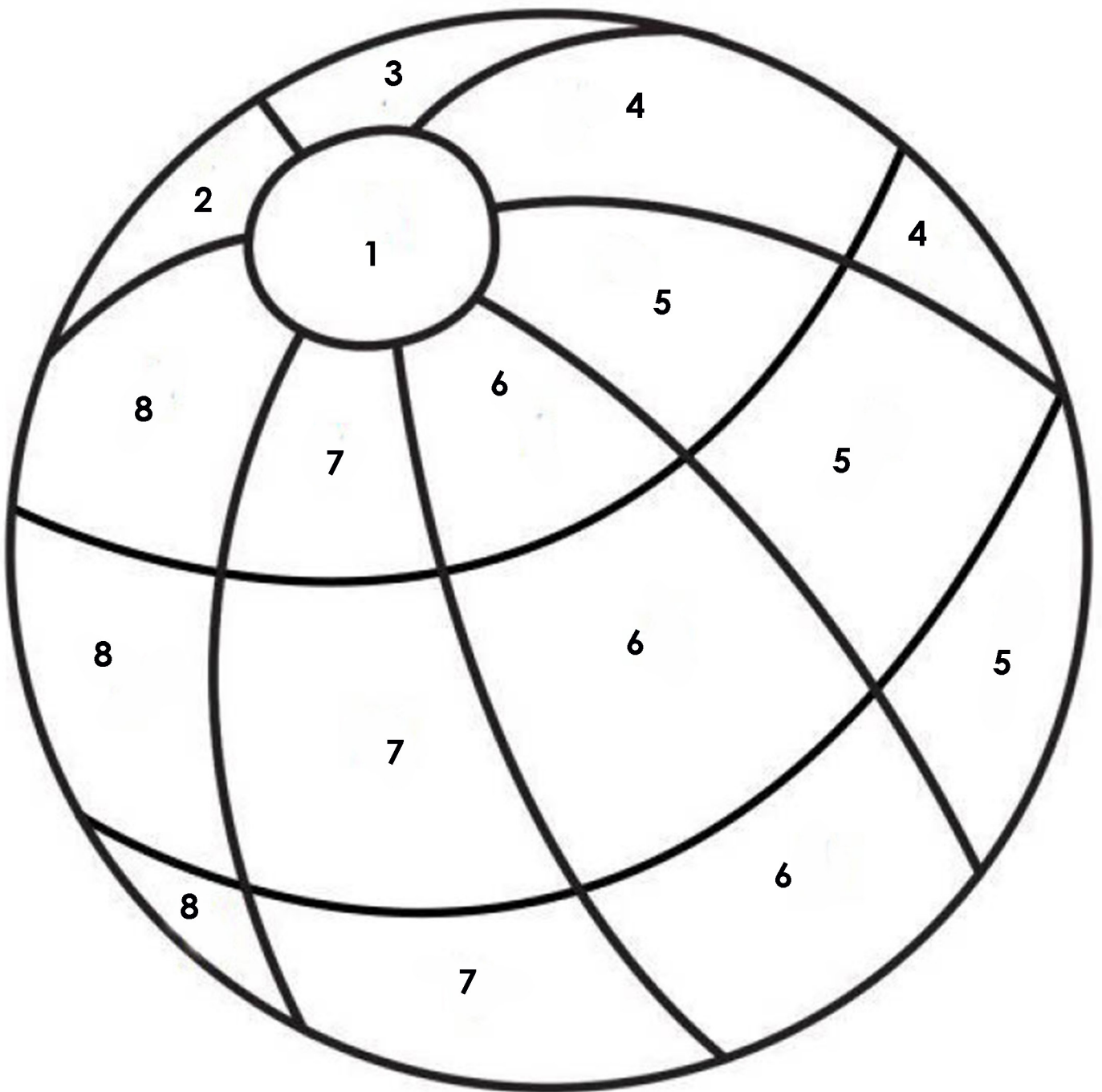

- 1
- 2
- 3
- 4
- 5
- 6
- 7
- 8
- 9
- 10

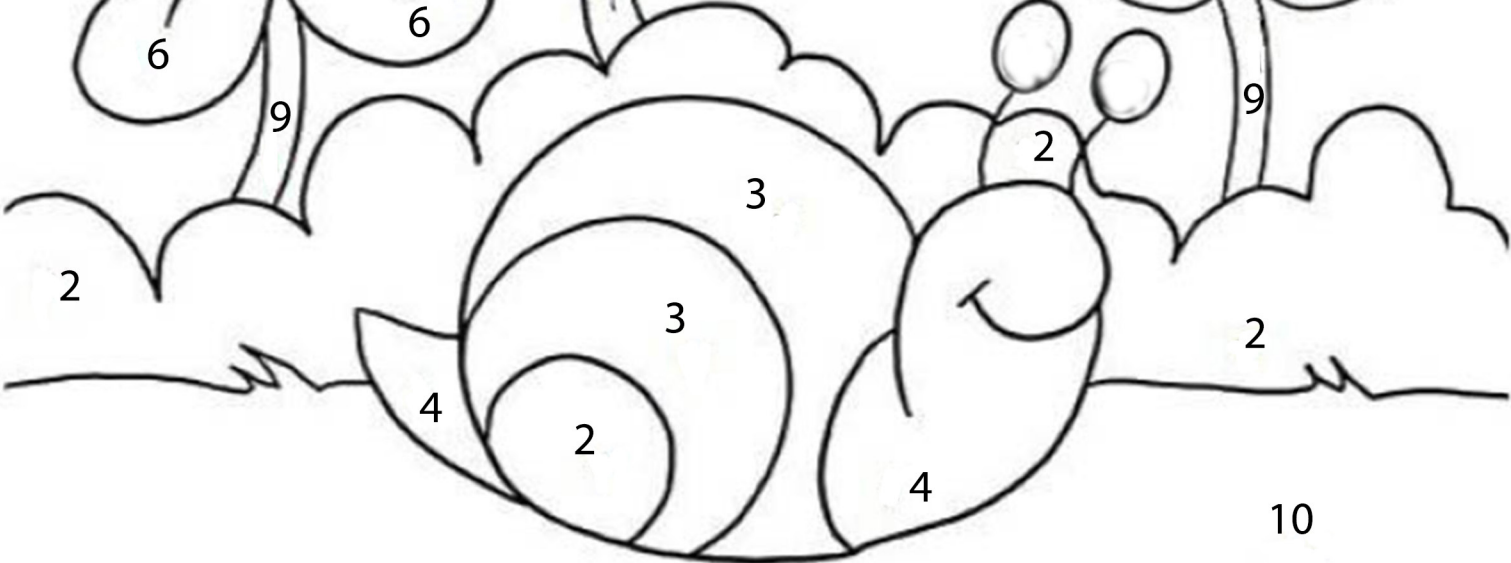
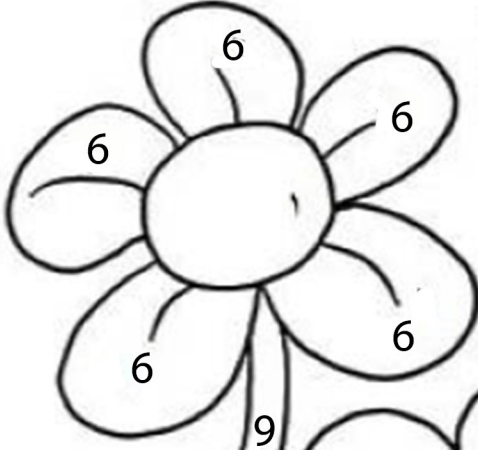
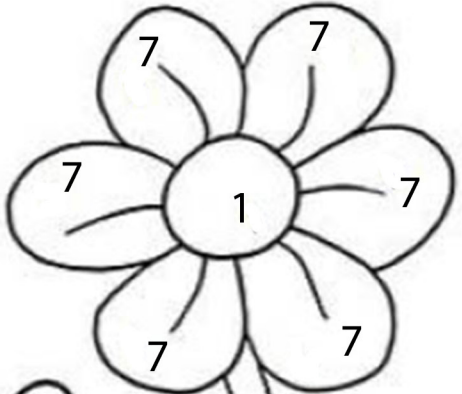
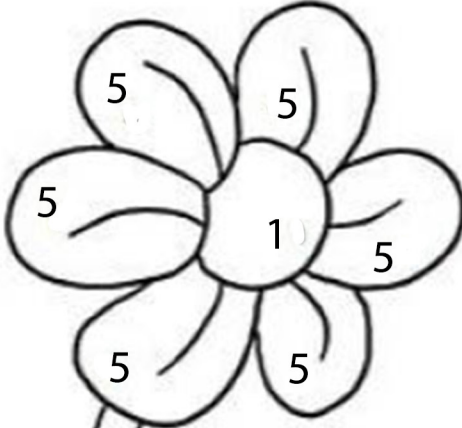
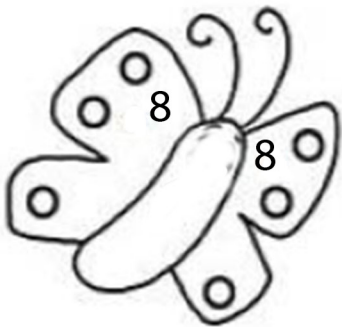
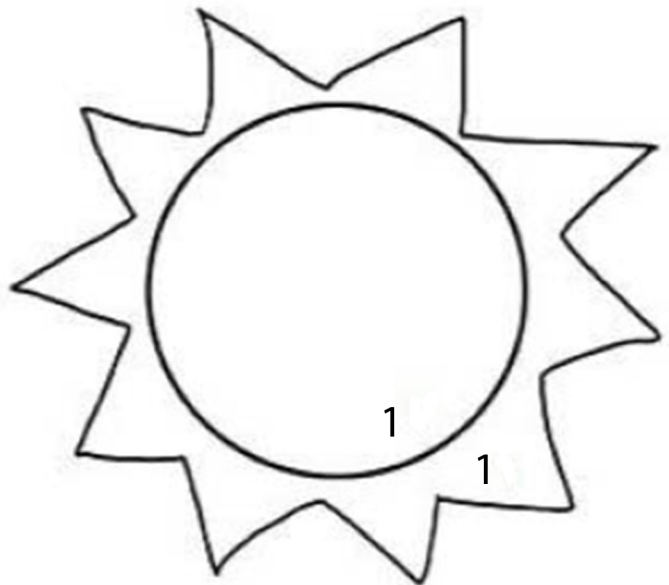

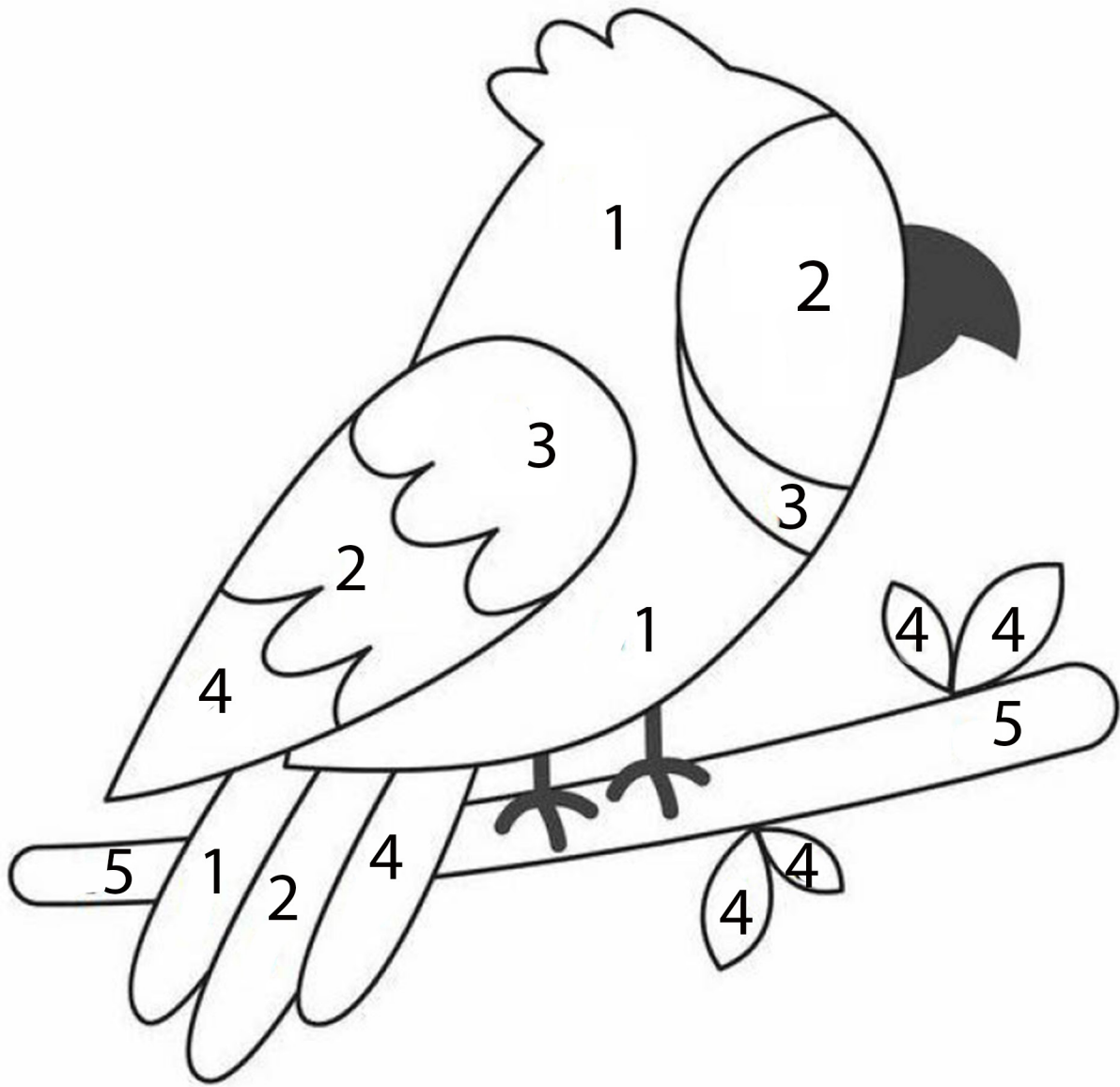

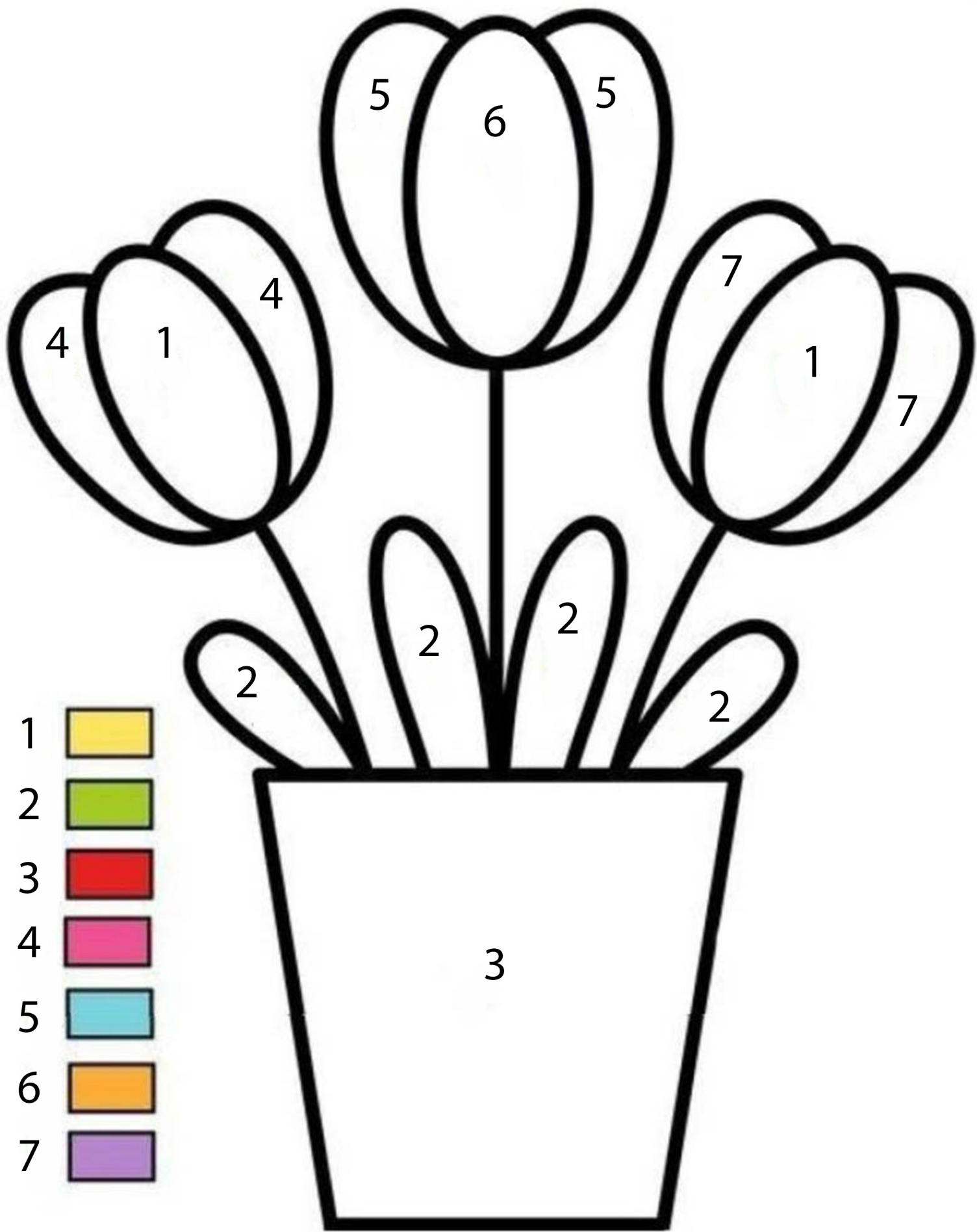



| | | | | | | | | | | | | | | |
|---|---|---|---|---|---|---|---|---|---|---|---|---|---|---|
| 1 | 1 | 1 | 1 | 1 | 1 | 1 | 1 | 1 | 1 | 1 | 1 | 1 | 1 | 1 |
| 1 | 1 | 1 | 1 | 2 | 1 | 1 | 1 | 1 | 1 | 2 | 1 | 1 | 1 | 1 |
| 1 | 1 | 1 | 2 | 1 | 2 | 1 | 1 | 1 | 2 | 1 | 2 | 1 | 1 | 1 |
| 1 | 1 | 1 | 6 | 1 | 1 | 2 | 1 | 2 | 1 | 1 | 6 | 1 | 1 | 1 |
| 1 | 1 | 1 | 1 | 1 | 1 | 5 | 5 | 5 | 1 | 1 | 1 | 1 | 1 | 1 |
| 1 | 5 | 5 | 1 | 1 | 5 | 5 | 5 | 5 | 5 | 1 | 1 | 5 | 5 | 1 |
| 5 | 6 | 7 | 4 | 1 | 5 | 2 | 5 | 2 | 5 | 1 | 4 | 7 | 6 | 5 |
| 5 | 7 | 7 | 4 | 4 | 5 | 5 | 7 | 5 | 5 | 4 | 4 | 7 | 7 | 5 |
| 5 | 4 | 4 | 5 | 4 | 4 | 6 | 6 | 6 | 4 | 4 | 5 | 4 | 4 | 5 |
| 1 | 4 | 4 | 4 | 4 | 4 | 6 | 6 | 6 | 4 | 4 | 4 | 4 | 1 | 1 |
| 1 | 1 | 1 | 3 | 3 | 3 | 6 | 6 | 6 | 3 | 3 | 3 | 1 | 1 | 1 |
| 1 | 1 | 3 | 3 | 3 | 3 | 6 | 6 | 6 | 3 | 3 | 3 | 3 | 1 | 1 |
| 1 | 3 | 3 | 7 | 3 | 3 | 6 | 6 | 6 | 3 | 3 | 7 | 3 | 3 | 1 |
| 1 | 3 | 5 | 3 | 3 | 1 | 6 | 6 | 6 | 1 | 3 | 3 | 5 | 3 | 1 |
| 1 | 3 | 3 | 3 | 1 | 1 | 1 | 1 | 1 | 1 | 1 | 3 | 3 | 3 | 1 |

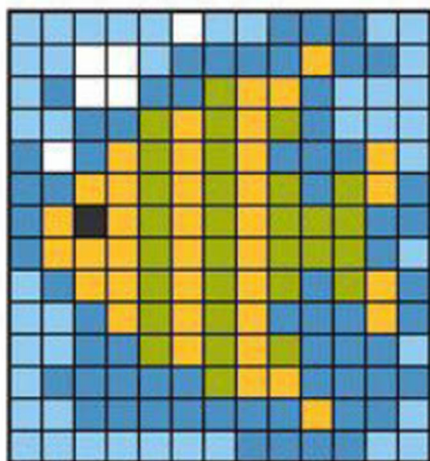

| | | | | | | | | | | | | |
|---|---|---|---|---|---|---|---|---|---|---|---|---|
| 2 | 2 | 2 | 2 | 2 | | 2 | 2 | 1 | 1 | 1 | 2 | 2 |
| 2 | 2 | | | 2 | 1 | 1 | 1 | 1 | 5 | 1 | 1 | 2 |
| 2 | 1 | | | 1 | 1 | 4 | 5 | 5 | 1 | 2 | 2 | 2 |
| 2 | 2 | 1 | 1 | 4 | 5 | 4 | 5 | 4 | 1 | 2 | 2 | 2 |
| 1 | | 1 | 5 | 4 | 5 | 4 | 5 | 1 | 1 | 1 | 5 | 2 |
| 1 | 1 | 5 | 5 | 4 | 5 | 4 | 5 | 4 | 1 | 4 | 5 | 1 |
| 1 | 5 | 3 | 5 | 4 | 5 | 4 | 5 | 4 | 4 | 4 | 1 | 1 |
| 1 | 5 | 5 | 5 | 4 | 5 | 4 | 5 | 4 | 4 | 4 | 1 | 2 |
| 2 | 1 | 5 | 5 | 4 | 5 | 4 | 5 | 4 | 1 | 4 | 5 | 1 |
| 2 | 2 | 1 | 5 | 4 | 5 | 4 | 5 | 1 | 1 | 1 | 5 | 1 |
| 2 | 2 | 1 | 1 | 4 | 5 | 4 | 5 | 4 | 1 | 1 | 1 | 2 |
| 2 | 1 | 1 | 1 | 1 | 1 | 4 | 5 | 5 | 1 | 1 | 1 | 1 |
| 2 | 2 | 1 | 1 | 1 | 1 | 1 | 1 | 1 | 5 | 1 | 1 | 2 |
| 2 | 2 | 2 | 2 | 2 | 2 | 2 | 1 | 1 | 1 | 1 | 2 | 2 |

We learned to color, compare,
distinguish, search, connect, and
draw, and we had a great
time!

لِلْعَالَمِينَ 

